



... it's the smile!

09/10



friendlyway arctic 32

Contents

Welcome to friendlyway	05
33 Good Reasons for friendlyway	06
friendlyway Systems Overview	12
friendlyway Software Overview	13
Application Areas	
Indoor Communication	16
Outdoor Communication	18
Tradeshow	19
Point-of-Sale	20
Premium Line	
friendlyway classic 17/19	24
friendlyway classic kids 17/19	26
friendlyway van 17	30
friendlyway waiter 17	34
friendlyway butler 17	38
friendlyway d-sign 12	42
friendlyway d-sign 32/40/52	46
friendlyway arctic 32	50
friendlyway impress 32L	54
friendlyway impress 40/52	58
friendlyway luminum 32/40	62
Professional Line	
friendlyway empire 19	68
friendlyway empire 22D	72
friendlyway welcome 32/40/52	74
friendlyway porter 19	76
friendlyway a-sign 12	78
friendlyway a-sign 32	80
Software	
friendlyway composer 9	84
Content Templates	92
Interactive Applications	93
Service	
friendlyway Projektentwicklung	98
Traditional Services	102
Professional Services	103
About friendlyway	109



Welcome to friendlyway



Dear Valued Customer
and Reader,

Come with us on a virtual „around the world in 80 seconds“ tour of friendlyway’s products. Any suggestions as to where we should visit? We will show you the locations where friendlyway’s products are already waiting for you. And now for two test questions: Does Kazakhstan come to mind? Or perhaps the Cayman Islands or Costa Rica? If not, don’t worry about it. As part of our expansion, we are always happy when we get orders from countries where we would like to deliver the product personally.

We take great pleasure in seeing how friendlyway’s products are increasingly making their mark in countries far away from Germany. With over 20,000 friendlyway solutions installed on all continents since the founding of the company, the products “with a smile” are among the best-selling of their kind. In 11 years, friendlyway has emerged as one of the leading providers of systems (see page 24 for kiosk systems and page 54 for digital signage), software (see page 84), and services (see page 98).

Our customers believe that friendlyway’s products are the result of the highest standards of quality and design as well as of friendlyway’s constant quest for innovation). friendlyway systems are assembled exclusively in ISO certified facilities in Germany. We set the highest standards for the quality of the materials used and care in the manufacture of our products. Granted, our products are not among the cheapest, but they are certainly the best of their kind (see page 109).

Take a look at friendlyway AG’s 11-year history of innovation (see page 116). Back in 2004, friendlyway was the first company to provide a large-screen display system with an integrated touch screen—the friendlyway impress 40. And now we’ve recently introduced the new friendlyway d-sign 52. Its elegant light metal casing with the trademark chrome strips by friendlyway features an integrated high-performance computer, a highly sensitive and precise touch screen, and a crystal-clear, bright, full HD flat screen (see page 46). Needless to say, the friendlyway composer 9 software package has been preinstalled on every friendlyway d-sign.

Incidentally, it has developed into one of the leading software packages for operating and updating display applications in both Europe and the U.S. The travel agency chain L’TUR just recently installed hundreds of advertising screens in its stores—all running the friendlyway composer 9. If Germany didn’t come to mind at the beginning of our 80-second trip around the world, just remember: the next friendlyway „product tour“ could begin at the German travel agency around the corner.

Your friendlyway team

A blue ink signature of Klaus Trox.

Klaus Trox

A blue ink signature of Karl Joachim Veigel.

Karl Joachim Veigel

33 Good Reasons for friendlyway



friendlyway - A Status Symbol of Success

1. The world's most successful brands opt for friendlyway: Rolex, Bentley, Swarovski, BMW, Mercedes Benz, Migros, Shell, Stanford University, Microsoft, Boeing, ebay, AOL, Yahoo, Nokia, Intel, and McDonalds are just a few examples of our extensive international customer base.

2. friendlyway terminals are deployed at the most exclusive locations and for the most exclusive people in the world. These are just some of our prominent customers:

- Juan Carlos, King of Spain; in Madrid
- Princess Camilla Parker Bowles & Prince Charles; on the HMS Scott
- Abdullah II, King of Jordan; in Amman
- Alia, Queen of Jordan; in Amman
- Crown Prince Abdullah bin Abd al-Aziz
- Royal Palace of Saudi Arabia; in Riad

3. In their field, many friendlyway systems are best-selling products—on a global scale. In Europe alone, more than 20,000 “friendlies” are currently deployed.

friendlyway - Timeless Design

4. The ultra-slim terminal design with a depth of just 4.7 cm never fails to impress.

5. Gently curved, tapered side panels emphasize the elegant product aesthetics.

6. Thin strips of chrome on both sides add a touch of excitement to an already impressive shell design.

7. Our globally patented design has remained a constant production feature throughout the years. Matching new units can be ordered anytime.

8. The award-winning design of friendlyway's products has found its way into locations such as the Museum of Modern Art in New York and San Francisco.

friendlyway - Reliability Through Quality

9. Only the finest materials are used in the production of friendlyway systems: chrome, anodized aluminum, stainless steel, safety glass.

10. On request, terminal surfaces can also be made of wood, silver, gold, or jewels (fractal design).

11. friendlyway only uses the latest crystal-clear, high-luminance active matrix displays.

12. friendlyway's outdoor products feature special displays designed for sunlight exposure.

13. friendlyway's products are manufactured and certified according to the highest quality standards, including DIN ISO 9001 and 9002.

14. All friendlyway products are tested for stability in mounted scenarios.

15. All friendlyway products are subjected to extreme tests in special climate chambers.

16. The friendlyway product range includes easy access (barrier-free) products as required by German law.

17. friendlyway products are tested and certified according to CE as well as the tough UL requirements in the U.S.

18. friendlyway's terminal shells are exclusively manufactured in Germany. The “Made in Germany” label is renowned for high quality and reliability.

19. friendlyway's products are based on a highly modular design. All components can be replaced or upgraded at any time.



20. friendlyway only uses powerful, state-of-the-art computers from renowned brands.

21. friendlyway only uses electronics components with extremely long life cycles. This guarantees future-proof investment.

22. Almost 100% of the materials used in friendlyway products can be recycled, which makes them a resource-friendly option.

23. More than 90% of all friendlyway systems manufactured to date are still fit for deployment. In terms of investment security as well as environmental friendliness, friendlyway's systems display excellent longevity.

friendlyway - Worldwide Support

24. friendlyway has more than 1,700 service partners in Germany alone. In addition, friendlyway has a global network of local partners who provide faultless service and support. friendlyway is one of the very few kiosk manufacturers who provide localized support for their internationally deployed products.

25. To guarantee the best worldwide service our telephone hotline is open from 08:00 am to 12:00 pm. We don't let you down.

26. Optionally, friendlyway can also provide permanent remote monitoring for deployed systems. This brings together security and reliability.

27. With friendlyway's three-year carefree support package, on-site service is provided at no extra charge.

28. friendlyway furthermore offers regular on-site inspections and cleaning. Naturally, installation and commissioning can also be provided.

friendlyway - Software & Hardware from a Single Supplier

29. friendlyway is a single supplier for software as well as hardware. The advantage of this is that all devices and applications are optimally matched and extensively tested for compatibility.

30. More than 100 combined years of technical development have gone into friendlyway's software solutions. Experiences made through numerous projects in Germany and internationally ensure ongoing improvements and system development.

31. In the rare event of a fault, friendlyway will provide the best possible support, regardless of whether the problems are caused by the hardware or the software.

friendlyway - Working With Our Customers and For Our Customers

32. The friendlyway team has had more than ten years of professional experience in the field, having designed, implemented, and supported over 400 major hardware and software projects.

33. friendlyway's company and service philosophy is to always stay one step ahead of the customer's expectations. Sustainable business success relies on ongoing improvement. The Japanese concept of "kaizen"—meaning "continuous process of improvement"—is evident throughout friendlyway's work and products.

Dr. Angela Merkel at the awards ceremony at the Paulskirche in Frankfurt

“Innovative companies like friendlyway are safeguarding jobs in Germany.”

friendlyway Facts & Figures

Average yearly growth of the kiosk and digital signage market, 1998–2009: approx. 20%

Average yearly turnover growth of the friendlyway corporation, 1998–2009: approx. 60%

Number of visitors to the friendlyway Web site in July 2006: approx. 23.000

Number of visitors to the friendlyway Web site in July 2009: approx. 53.000

Number of product variations offered by friendlyway in 1998: 25

Number of product variations offered by friendlyway in 2009: 8.820

Number of countries that friendlyway products were supplied to in 1998: 4

Number of countries that friendlyway products are being supplied to in 2009: 49

Average service life of a light bulb: 2.000 hours

Average service life of a computer: 7.920 hours

Average service life of a friendlyway classic system: 34.944 hours

Number of parts in a mechanical Swiss clockwork: approx. 500

Number of parts in a friendlyway arctic system: approx. 2.500

Price of the same Swiss clockwork: EUR 13.250

Price of a friendlyway arctic system: EUR 19.650

Number of friendlyway solutions installed around the world in 1998: 20

Number of friendlyway solutions installed around the world in 2009: 20.000 plus

friendlyway employees' average amount of market experience in kiosks and digital signage: 10 years

friendlyway employees' average age: 39 years

Number of code lines contained in friendlyway software in 2002: 31.325

Number of code lines contained in friendlyway software in 2009: 570.800

Success is a Matter of Presentation

friendlyway Ensures an Elegant and Impressive Appearance



If you want to capture your audience's imagination at trade-shows and events, infotainment is the solution. Today's innovative media technologies offer completely fresh ways of establishing a convincing company presence in the public eye. With multimedia product presentations and interactive content communication, you can create unique impressions that your customers and business partners will remember well beyond the event.

Turn to friendlyway to present your company and your products on the digital stage! We are a renowned specialist in the development and marketing of standard software and system solutions for digital advertising displays and interactive kiosk systems. friendlyway's specially developed technological solutions for advertising have been marketed in Europe, Asia, and the U.S. since the 1990s. Today, friendlyway's info terminals have become sought-after status symbols in the field of digital signage and interactive information management.

Our system solutions are your key to successful interactive customer communication. friendlyway's terminals and digital signs are state-of-the-art network-based systems of information dissemination. In addition to hardware, we provide a versatile range of proprietary software solutions for our systems. Every single one of our products features an unmistakable and elegant design. Our terminals are equally suited for deployment at trade-shows, events, and conferences, or as greeting points and info stations on your company premises.

Most friendlyway systems are now also available as rentals. If you opt for friendlyway's Full Service package, we will deliver the specified systems to your deployment location, load up the software, and commission the systems. In addition, we will remotely monitor the systems throughout the event and pick them up on conclusion.

Please do not hesitate to contact us directly—we will gladly put together a solution with you that meets all of your requirements. We look forward to hearing from you!

friendlyway AG

Feringastr. 9, 85774 Unterföhring, Germany

Tel: +49 (0) 89 95 97 91 340, Fax: +49 (0) 89 95 97 91 40

E-mail: info@friendlyway.com

Internet: <http://www.friendlyway.com>



What we offer:

- Presentation and information media systems for trade-shows, events, promotional campaigns, and conferences; permanent installation in stores and entrance areas
- Delivery and pick-up of systems
- Installation and service
- Terminal design according to your corporate design specifications
- Software to prevent hacker access; includes restricted browsing zones and operating system shielding (friendlyway secure browser 9)
- Software for compiling and controlling digital presentations (friendlyway composer 9)

What our terminals offer:

- Internet access via DSL, LAN, or WLAN
- Playback of PowerPoint presentations
- Local video playback (DVD)
- Brochure mail-outs via e-mail
- "On demand" brochure printouts
- Visitor registration
- Visitor surveys
- Navigation systems
- Presentation of trade-show content
- Presentation of competitions / sweepstakes
- Live TV
- Simultaneous presentation of Internet and TV content
- PDA downloading
- Many other features!

friendlyway Systems

friendlyway systems are characterized by excellent design, advanced technical stability, excellent value to performance ratio. For more than 10 years, our customers have relied on our high level of competence. Our product lines - the *Premium Line* and the *Professional Line* – make it possible for you to identify the best product suitable for your project. You can also lease friendlyway systems. Contact us!

Premium Line



The *Premium Line* meets all requirements of a top quality designed system (aluminium housing), which feels at home in almost any surrounding. The high quality workmanship is noticeable at first sight. And despite high quality design standards, one does not have to forego the latest technologies.

- Stylish & unique design
- Flexible configurations
- Operator & service friendly
- Future-oriented to the latest state of technology
- An eye-catcher at every event
- Highest quality standards

Professional Line



With the *Professional Line*, we have placed special emphasis on the combination of efficiency, high added value and operational capability in the harshest environment (powder-coated metal). Ideal for a carefree roll out even in larger quantities as well as the implementation of highly complex projects.

- Compact, robust and representative design
- Competitive pricing, designed for larger roll outs
- Flexible configurations
- Designed for application-oriented computers
- Operator & service friendly
- Current state of technology

We are available for a discussion about your project ideas; you will see that we will have a solution even for your project.

friendlyway Software

friendlyway's composer 9 system, provides an up-to-date solution portfolio, that is unique in functionality as well as in operational performance.



friendlyway secure browser

- Makes it possible to run Web applications & interactive applications on kiosks or PC's
- Prevents random access to the operating system by the user
- Offers a customizable user interface



friendlyway player 9

- Seamless playback of multimedia digital signage presentations
- Support for Windows XP, Vista & Windows XP Embedded
- Developed to function in 24x7 mode



friendlyway composer network services

- Automatic distribution of content to kiosks or player displays
- Monitoring of operational readiness of kiosks or player displays
- Proof-of-play reports and/or utilization statistics for kiosks and displays



friendlyway composer 9

- Creation of digital signage content from a variety of multimedia formats
- Enables splitting the screen into several areas to display their own content
- Automatic calculation of display time for the presentation
- Scheduling of content by day, week or month

Software Capacities

User friendly control of media formats

The friendlyway software utilizes a wide variety of media formats in different screen zones seamlessly and efficiently. The user friendly software reduces training costs and clearly simplifies the complex subject of media control.

Network Management

The friendlyway software enables transmission of content and visual monitoring of stations with just a few mouse clicks. The software is suited for all network sizes and can also be used as an ASP version.

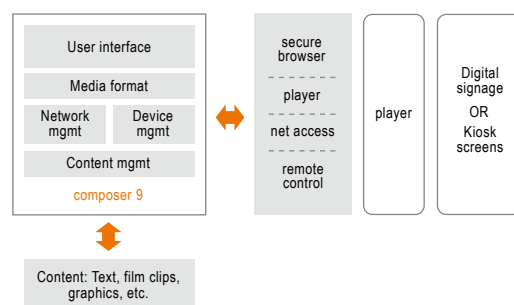

Kiosk browser

The friendlyway software protects the kiosk or computer from access by unauthorized users and allows execution of kiosk applications in an optimized environment for the public domain.

Applications



Indoor Communication

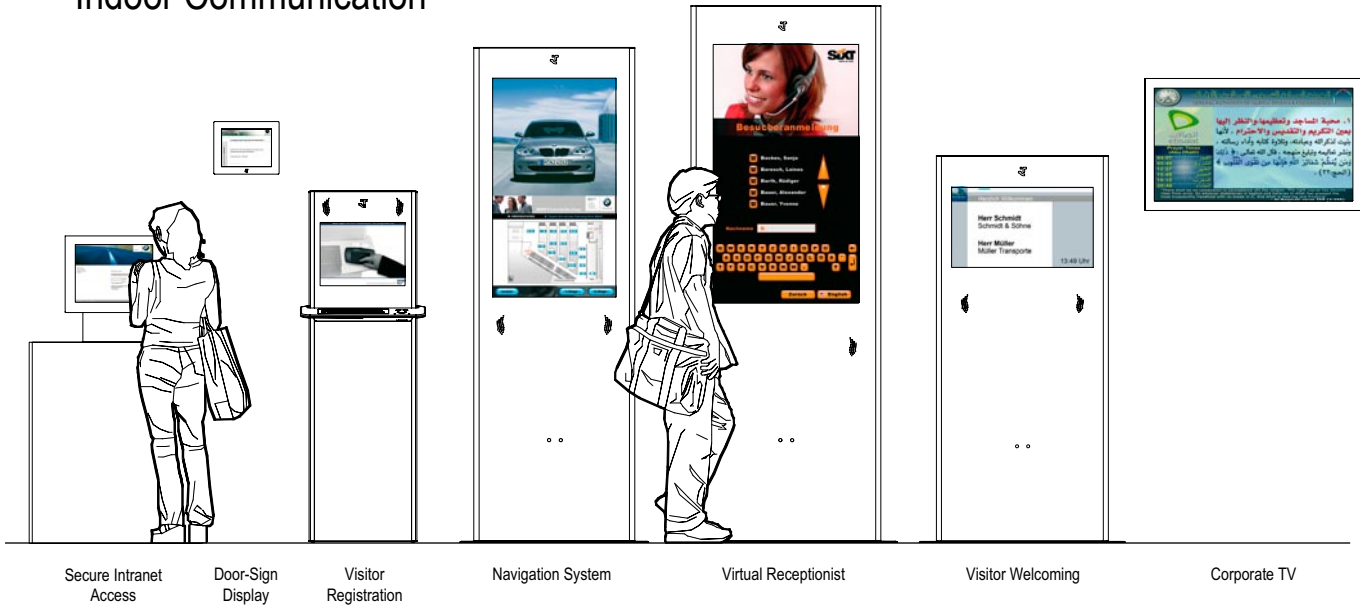

Secure Intranet Access

Door-Sign Display

Visitor Registration

Navigation System

Virtual Receptionist

Visitor Welcoming

Corporate TV



Secure Intranet Access

Do some of your employees not have their own computer workstation? Have all your employee processes (vacation requests, etc.) been transferred into the company intranet? With friendlyway's kiosk products, you can now open up the intranet to all your employees—in the cafeteria, staff lounge, or on the shop floor. Access to the kiosk terminal can be strictly personalized with the recognition system using employee ID cards. In this manner, employees access only the information that is intended just for them.



Corporate TV

Sharing information regularly with your employees is an important aspect of modern business, and one that is all too often neglected. With friendlyway's "Corporate TV" solution, you can share company information with your employees using your own company TV channel. The friendlyway composer 7 standard software enables the broadcasting of important company news, meaning it can be easily operated and automatically updated. Thus you save money during the operation of your display network and can inform your employees directly and without delays.

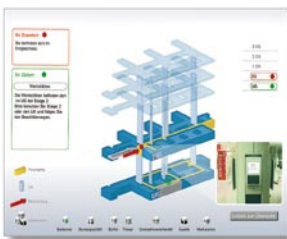

Mobile Object Information

The disadvantage of stationary navigation guides is that visitors either need to possess an excellent memory or be physically handed a map. With friendlyway kiosks, your visitors will get a mobile navigation guide to carry with them. The navigation system periodically determines its current position via a mobile RF chip and downloads updated information via a wireless connection. As a result, your visitors always receive the right navigational guidance at the right point (e.g., right / left arrow at the end of a corridor).



Virtual Receptionist

Your entrance area is not permanently staffed by a receptionist? No problem! friendlyway impress or friendlyway classic lets your visitors select their contact person directly via the touch-sensitive display panel of your friendlyway system. The telephone connection to the employee in question is established at the touch of a finger. Optionally, this solution can also include video telephony; in this case, the employee can visually identify the visitor via the friendlyway system.



Door-Sign Display

Today's door signs are digital! Not only is this new and innovative, it is also highly useful. Manually changing door-signs can be a time-consuming and costly process if your premises has a large number of rooms that frequently change occupancy. With the friendlyway d-sign and the friendlyway composer 7 software this process is digitalized and automated. Room booking data is automatically imported from a dedicated web application or directly from your Outlook calendar. This data is then formatted according to your company design specifications and transferred to your electronic door signs. This process greatly simplifies administration, and it also illustrates your business innovation.



Visitor Registration

Visitor registration is an important part of your business processes, and it should be optimized accordingly—using, for example, friendlyway classic with a business card reader. This solution facilitates fast and simple capturing of visitor data via a reader or via manual keyboard entry. This way, you will always be fully informed about visitor numbers and other visitor details. The captured data can be electronically and instantly transferred to your CRM Customer Loyalty System. In addition, the captured visitor data can be used to generate visitor passes automatically. This is an elegant solution that will also enhance your next trade-show appearance.



Navigation System

Today's modern navigation systems are now also available for buildings. Already a standard feature in most cars, route guidance is a service that should also be available to your visitors. friendlyway impress is an elegantly designed application that provides your visitors with a visual guide to your company premises. We will integrate both your building plans and your design into our tailor-made application for you. Visitors need only to touch one of the touch-sensitive display panels of the friendlyway system, and the shortest route to their contact person is immediately calculated and displayed. Your visitors will not fail to be impressed!



Visitor Welcoming

First impressions are vital. The way you welcome your visitors represents your company's style and public appearance. With friendlyway's digital signage products, you can update your visitor schedule quickly and easily, and always have the name of the next visitor ready on the digital sign in your foyer. The illustrations on the left depict examples of designs that have been implemented for existing customers.

Outdoor Communication

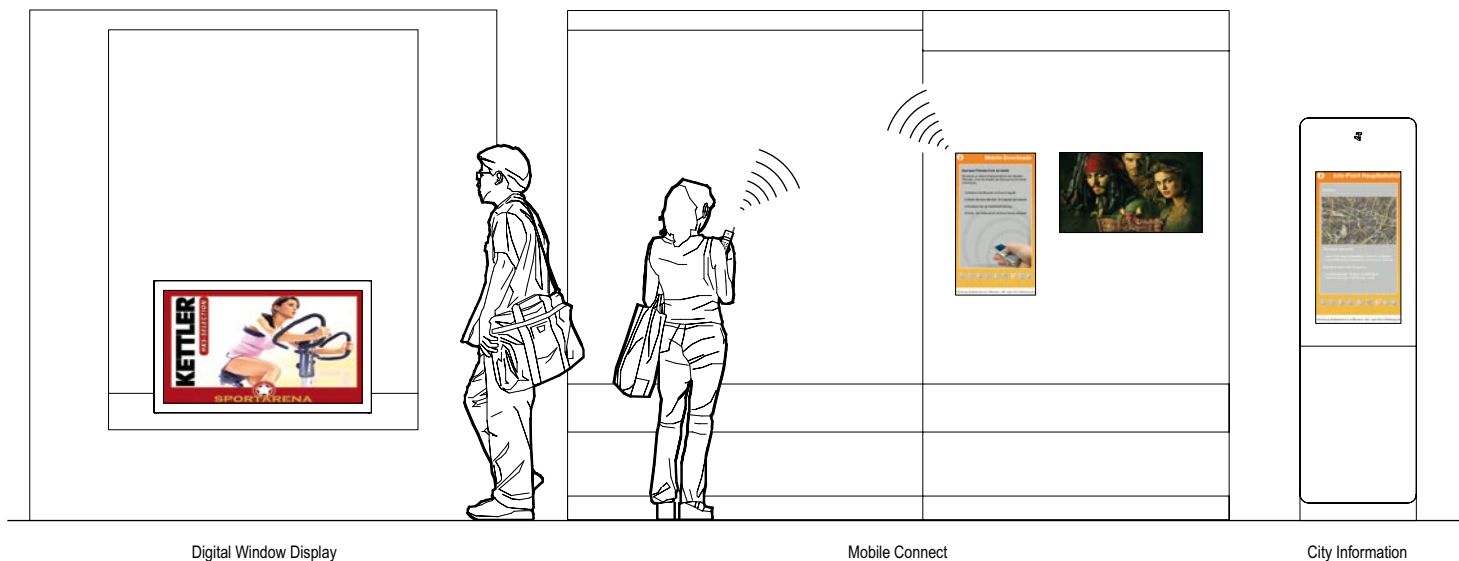

Digital Window Display

Mobile Connect

City Information

Digital Window Display

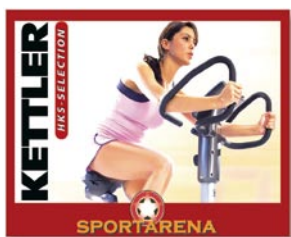

Shop windows are going digital. More and more stores have screens playing back content behind their shop windows. By day as well as by night, customers are drawn to the new medium, finding out about restaurant specials, real estate and new banking offers outside of normal opening hours. In order to make the implementation of your digital window display as simple as possible, we have developed a particular solution for you at friendlyway. Combined with the friendlyway composer 7 software, the “Digital Window Display” solution lets you compile your window display showreels easily—entirely within your own design parameters. Let us know what your intentions are for your digital display window.

Mobile Connect



How can you provide information to mobile target groups without having to rely on costly and time-consuming print media? The friendlyway arctic system is the answer. Using standard wireless transmission methods such as wi-fi, Bluetooth, or infrared, you can immediately transmit your content automatically. Mobile Connect dynamically pre-formats your data for targeted mobile user devices and lets you display any image, text, video, or audio content. Most major cities in Germany provide their citizens and visitors with street maps at their public info terminals. The map sections displayed often also include local service advertising and offers, e.g., for restaurants, dry cleaners, etc. Once the user has selected an offer, he/she can download to their mobile phone the address and a map with a route description.



City Information

More and more cities and towns are deciding to install public info terminals. Citizens are to be given the opportunity to learn about current events and offers without requiring their own Internet connection, and to freely access the electronic services offered by public authorities. In addition, tourists should also receive up-to-date information about local sights and attractions. With its fully outdoor-capable display systems, friendlyway makes it possible to provide professional offers for your community.

Tradeshow

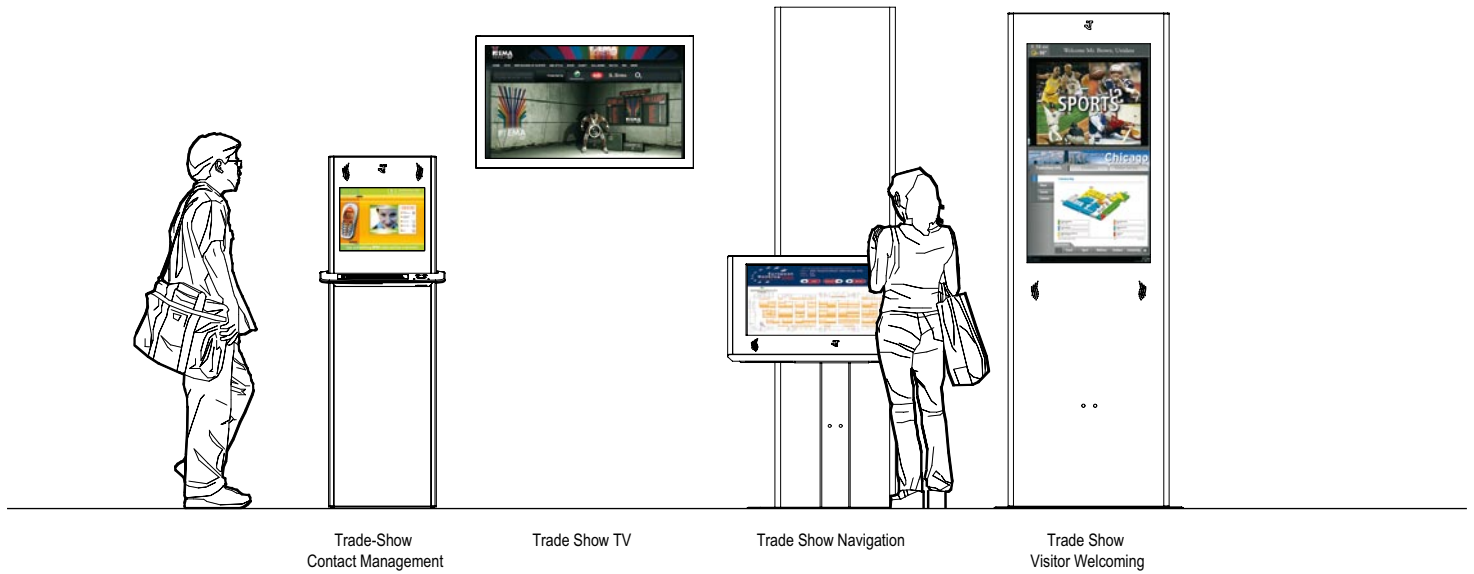

Trade-Show
Contact Management

Trade Show TV

Trade Show Navigation

Trade Show
Visitor Welcoming



Trade Show Visitor Reception

When your company attends in a trade show, do your days mostly consist of one meeting after another? That is a good thing. That's what a trade show is about. To make your visitors still feel welcome despite the hectic pace, friendlyway offers you highly attractive displays with the friendlyway impress or the friendlyway d-sign systems to greet your visitors. Therefore, you can make sure that your customers are personally greeted on all displays or at a selection of specific welcome displays.

Contact Detail Entry at Trade Shows



At the end of a trade show, do you know which customers visited your stand and when? Given the investment that every trade show appearance involves, is it not particularly important to have transparency here too? All too often, business cards disappear never to be seen again into jacket pockets of the people manning the booth. Using friendlyway classic with a business-card reader, you will be better able to manage your contact data at trade shows and events. With the help of the business-card reader, contact details are automatically saved in an electronic database. So, on the same day, more marketing documents can be sent to interested parties by mail. That's impressive.

Trade Show Navigation

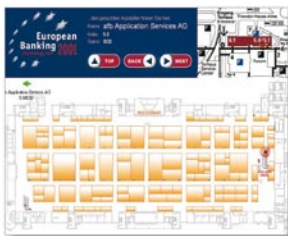

Long lines form in front of information booths at trade shows. We have already gotten used to this sight. In fact, a major trade show would be inconceivable without those endless visitor lines. However, there is a better and more cost-efficient alternative: friendlyway impress, for example, guides visitors of your trade show directly to the booths they wish to view. Visitors can even interactively select several different exhibitor destinations. The application automatically calculates the best walking route and depicts it as an easy-to-read map. The calculated routes can also be printed out at the press of a button.

Trade Show TV



Offer your trade show visitors something special! The stunningly brilliant friendlyway d-sign displays when combined with the friendlyway composer 7 software will turn your next trade show appearance into an impressive multimedia experience. You can tailor your company content exactly to your different target groups, play back your presentations accordingly—and decide which content appears on which display.

Point-of-Sale

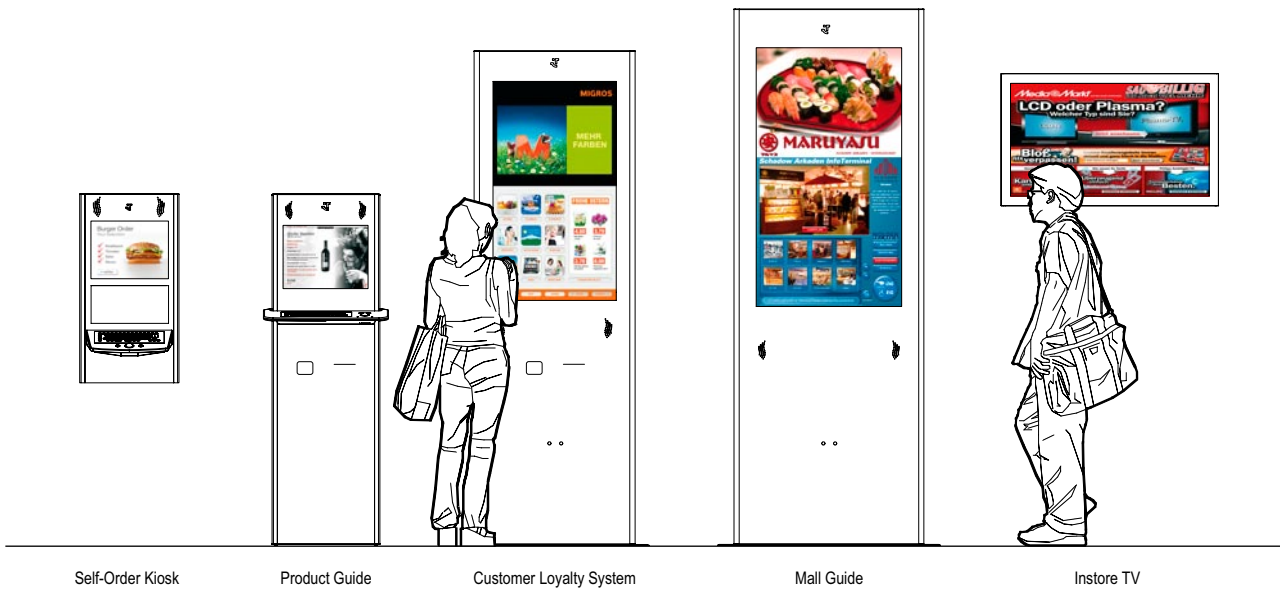

Self-Order Kiosk

Product Guide

Customer Loyalty System

Mall Guide

Instore TV



Self-Order Kiosk

Don't want to stand in line? Then simply place your order with the touch of a finger. Pay immediately and then with the printed receipt go directly to the goods collection area. Customer service is becoming faster and, above all, better. What's more, the Self-Order kiosk saves costs. Numerous restaurant chains are already relying successfully on Self-Order kiosks. The investment in this infrastructure pays for itself after just 6 to 9 months.



Product Guide

After introducing a digital product guide, one of our customers from the toy sector managed to increase turnover by 147% for the targeted products within four weeks. This is a great achievement, and a good incentive to take advantage of friendlyway's "Product Guide" solution. The Product Guide application identifies products by their barcode (or in the future via RF chip recognition) and retrieves the corresponding product information from a database. The Product Guide application also has comprehensive functions for accessing all common ERP systems. This makes content updating not only easy and automatic, but also very cost-efficient.



Customer Loyalty System

Do you actively market your store to customers in order to create customer loyalty? If so, you will know that sustainable results can only be achieved through a high level of customer engagement. An example of this is to offer customers surprise discounts or bonuses when they repeatedly visit your store. Using friendlyway impress, you can identify your customers via their customer card. After analyzing the customer profile, the application presents specific sales recommendations and suggestions for discounts based on this profile. This is the kind of service that customers appreciate immensely, as it addresses them on a personal level—not unlike the friendly neighborhood storekeeper of old. The Customer Loyalty System interfaces seamlessly with all common CRM applications, which makes profile updating more cost-efficient.



Mall Guide

There is a phenomenon in the U.S. that has spread to Europe in recent years—the shopping mall. Gigantic malls have been opening everywhere—many containing a mix of independent stores and chain stores. Faced with a plethora of products, customers can easily lose track of what is available and where. friendlyway impress provides easy mall navigation for customers and lets them quickly locate their desired products and promotions. This is a service that costs very little and that will pay for itself in no time. Numerous malls have even opted to use the friendlyway impress kiosk system as the hardware running their Mall Guides.



Instore TV

Advertise your current offers with the friendlyway d-sign. Using the friendlyway composer 7 standard software, we create an in-store TV program specific to your needs. Using this software, you can communicate specific content at specific times to different customers when they are in your store. This is one investment that you will never regret.

Premium Line



friendlyway classic 17/19

An Elegant Classic

The most widely sold kiosk system in Europe, the friendlyway classic 17/19 has become a benchmark for modern info terminals.

The friendlyway classic 17/19 marries function with elegance. Featuring a 4.7-cm slim housing with a surface made of anodized aluminum or high-gloss lacquer, this unit blends perfectly into any surroundings.

Thanks to a wide range of keyboard and touch-screen options, the classic 17/19 offers superb flexibility. Powerful integrated computer technology guarantees flawless operation for all your applications.

The friendlyway classic 17/19 is ideally suited to trade-shows and presentation events. Thanks to its unique design, transport is quick and easy, and the kiosk is very sturdy when mounted on location.

The friendlyway classic 17/19 is designed as a modular system: this kiosk can be tailored completely to your individual requirements. To fully personalize the classic 17/19, you can optionally add a foil label to the shell featuring your company designs.



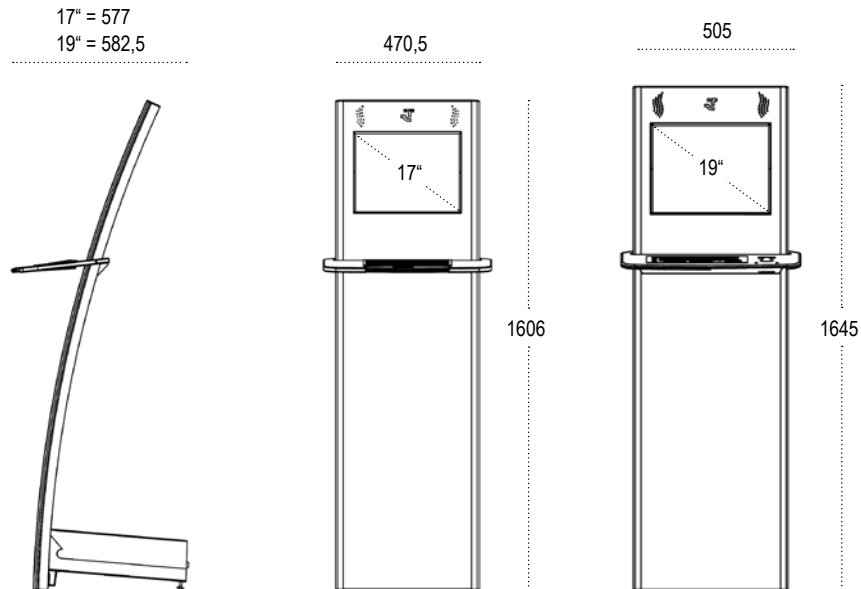

Technical Data

friendlyway classic 17/19

Specifications

17" (resolution: 1280 x 1024 pixels)
 • 470,5 * 1606 * 577 mm (width * height * depth), 35 kg
 • View angle: 160° / 160°

19" (resolution: 1280 x 1024 pixels)
 • 505 * 1645 * 582,5 mm (width * height * depth), 40 kg
 • View angle: 178° / 178°

- Luminance: 300 cd/qm
- Touch option: SAW, Surface Acoustic Wave
- CPU: Small Form Factor PC, Dell™ Optiplex™ 760 (or comparable performance)
- Housing: Anodized aluminum front panel, chrome-plated side panels
- Power supply: Intern 85 - 265 VAC
- Ambient temperature: +5°C - +35°C
- Location: Indoor

Highlights

- Elegant designer shell
- Anodized aluminum front panel
- Chrome-plated side panels
- Brilliant 17" or 19" display

Special Equipment

- Touch screen (normal or shock resistant)
- Integrated hi-fi loudspeakers
- Keyboard (plastic or vandal-proof stainless steel)
- Business-card scanner (integrated in keyboard)
- Wireless networking (WLAN)
- Bluetooth functionality
- Webcam
- Ultrasonic proximity sensor
- Foil label to personalize the kiosk with your corporate identity
- Custom terminal color scheme in any RAL color
- Further configuration options on request

Areas of Application

Trade fair, retail store, museum (exhibition), waiting room solution, cueing system, virtual registration and reception kiosk

friendlyway classic kids 17/19[®]



friendlyway classic for kids

Because friendlyway products are among the longest-lived IT products around, we have developed friendlyway classic kids. It offers children the same service that adults have been able to enjoy for the past 10 years.

That way, the kids will not then need to become acquainted with a new system as adults. friendlyway classic for adults will continue to be available – with the latest technology, of course. You can rightly expect that from a friendlyway product.

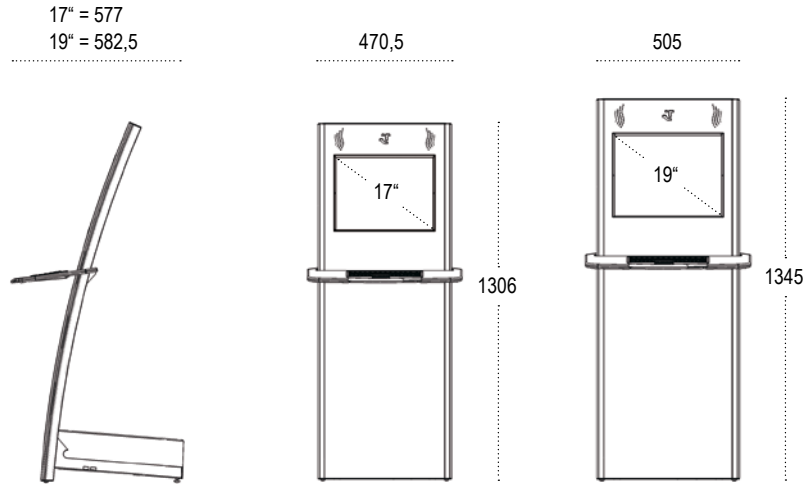

Technical Data

friendlyway classic kids 17/19

Specifications

- 17" (resolution: 1280 x 1024 pixels), 30 kg
- 470,5 * 1306 * 577 mm (width * height * depth)
- View angle: 160° / 160°

- 19" (resolution: 1280 x 1024 pixels), 33 kg
- 505 * 1345 * 582,5 mm (width * height * depth)
- View angle: 178° / 178°

- Luminance: 300 cd/qm
- Touch option: SAW, Surface Acoustic Wave
- CPU: Small Form Factor PC, Dell™ Optiplex™ 760 (or comparable performance)
- Housing: Anodized aluminum front panel, chrome-plated side panels
- Power supply: Intern 85 - 265 VAC
- Ambient temperature: +5°C - +35°C
- Location: Indoor

Highlights

- Elegant designer shell
- Anodized aluminum front panel
- Chrome-plated side panels
- Brilliant 17" or 19" display

Special Equipment

- Touch screen (normal or shock resistant)
- Integrated hi-fi loudspeakers
- Keyboard (plastic or vandal-proof stainless steel)
- Business-card scanner (integrated in keyboard)
- Wireless networking (WLAN)
- Bluetooth functionality
- Webcam
- Ultrasonic proximity sensor
- Foil label to personalize the kiosk with your corporate identity
- Custom terminal color scheme in any RAL color
- Further configuration options on request

Areas of Application

Trade fair, retail store, museum (exhibition), waiting room solution, Cueing system, virtual registration and reception kiosk



WELCOME
TO THE WORLD CHAMPIONSHIP



www.skoda-auto.cz

Air Dolomiti - Partner of Lufthansa, Munich, Germany

“Two kiosks from friendlyway’s ‘Classic’ range have been gracing our Italian-themed ‘Spacio Italia’ lounge in the departure area of Munich Airport’s Terminal 2. Our passengers can use these terminals free of charge for Web browsing. Internet connectivity is provided at full broadband speed via UMTS. The attractive design of our new surf stations and friendlyway’s renowned reliability match our company image perfectly.”

friendlyway van 17[®]

A Slim All-Rounder

The friendlyway van 17 combines the design of the classic 17/19 with a spacious housing to accommodate the modular design of modern high-performance kiosk systems.

Nearly all common hardware peripherals (printer, barcode reader, card scanner, webcam, etc.) can be integrated in the kiosk side by side. The built-in multifunction front panel lets you update components and peripherals at your own pace and without having to send in the terminal.

Despite its spacious design for technological extensions, the friendlyway van 17 is slim and elegant in appearance. Thanks to built-in floor brackets, the friendlyway van 17 always stands its ground—even in high-traffic public locations.

The kiosk can easily be adapted to your company's corporate identity thanks to illuminated advertising panels, individual labeling, and colored paintwork options.



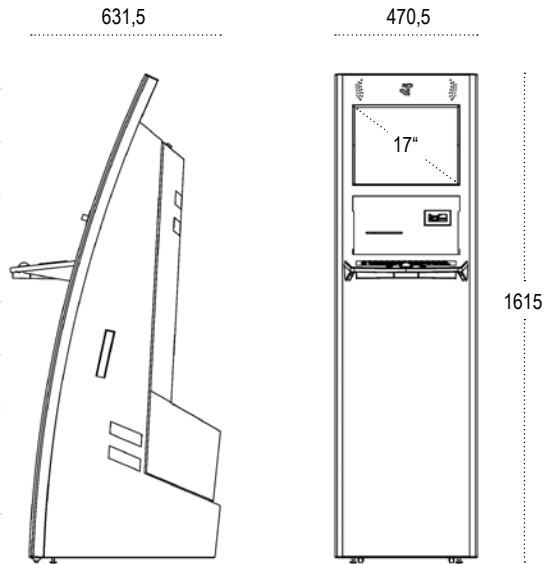

Technical Data

friendlyway van 17

Specifications

- 17" (resolution: 1280 x 1024 pixels)
- 470,5 * 1615 * 631,5 mm (width * height * depth), 60 kg
- Luminance: 300 cd/qm
- View angle: 160° / 160°
- Touch option: SAW, Surface Acoustic Wave
- CPU: Small Form Factor PC, Dell™ Optiplex™ 760 (or comparable performance), as well as mini Tower
- Housing: Anodized aluminum front panel, chrome-plated side panels, powder-coated metal rear panel
- Power supply: Intern 85 - 265 VAC
- Ambient temperature: +5°C - +35°C
- Location: Indoor

Highlights

- Elegant designer shell
- Anodized aluminum front panel
- Chrome-plated side panels
- Brilliant 17-inch display

Special Equipment

- Touch screen (normal or shock resistant)
- Integrated hi-fi loudspeakers
- Keyboard (plastic or vandal-proof stainless steel)
- Magnetic strip and chip card reader
- Thermal printer (58 mm to DIN A4)
- Laser printer
- Webcam
- Ultrasonic proximity sensor
- Barcode reader
- DVD burner
- Memory card reading device
- Payment functions (coin and bank note verification)
- Wireless networking (WLAN)
- Telephone options (analog and VoIP)
- Illuminated advertising panel for personalized designs
- Foil label to personalize the kiosk with your corporate identity
- UPS (uninterrupted power supply)
- Further configuration options on request

Areas of Application

Point of Sale (further configuration options adaptable to your applications), trade fair kiosk, navigation system, retail store terminal, cueing system, contact management system

CarExpress Automat



SIXT
rent a car



Sixt AG, Pullach, Germany

“As a partner, friendlyway AG helps us to implement our innovative ideas and place them on the market very quickly. The professional quality and elegant modern design of our Virtual Counters and CarExpress kiosks aptly demonstrate our leading position in the vehicle rentals sector.”

friendlyway waiter 17[®]



The Compact Kiosk Solution

The friendlyway waiter 17 makes a big impression even in the smallest of spaces, be it a small retail outlet or a waiting room. This info terminal is based on a wall-mounted design for maximum economy of space.

Despite its compact dimensions, the friendlyway waiter 17 offers all the advantages of a fully fledged friendlyway kiosk. The waiter 17 has an attractive surface made of anodized aluminum or high-gloss lacquer, and its rugged design protects it against vandalism.

The integrated multifunction front panel lets you install a range of hardware peripherals, up to and including an A4 printer. Individual components and peripherals can be exchanged at any time with minimal effort.

An integrated heating element (optional) means that the kiosk can also be mounted in covered outdoor areas. The outdoor version of the friendlyway waiter 17 additionally features a glass roof.

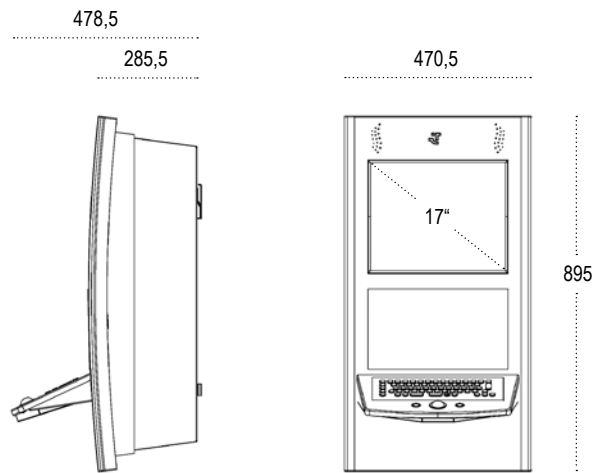

Technical Data

friendlyway waiter 17

Specifications

- 17" (resolution: 1280 x 1024 pixels), 50 kg
- 470,5 * 895 * 285,5 mm (width * height * depth)
- Luminance: 300 cd/qm
- View angle: 160° / 160°
- Touch option: SAW, Surface Acoustic Wave
- CPU: Small Form Factor PC, Dell™ Optiplex™ 760 (or comparable performance)
- Housing: Anodized aluminum front panel, chrome-plated side panels, powder-coated metal rear panel. The terminal can be unlocked on the side and opened from the front. The stable hinge drive mechanism is suitable for rugged applications.
- Power supply: Internal 85 - 265 VAC
- Ambient temperature: +5°C - +35°C
- Location: Indoor or semioutdoor, wall-mount

Highlights

- Unsurpassed design
- High-end construction
- Versatile
- Reliable component assortment
- Latest CPU technology
- Numerous configurations available
- Quick and simple integration of customer-specific hardware

Special Equipment

- Integrated hi-fi loudspeakers
- Touchscreen (normal or shock resistant)
- Keyboard (plastic or vandal-proof stainless steel)
- Magnetic strip and chip card reader
- Thermal printer (58 mm to DIN A4)
- Payment functions (coin and bank note verification)
- Wireless networking (WLAN)
- Telephone options (analog and VoIP)
- Webcam
- Barcode reader
- Foil label to personalize the kiosk with your corporate identity
- Heated system
- Further configuration options on request

Areas of Application

Visitor welcome station, information kiosk, information kiosks, virtual concierge solution, employee terminal, navigation system, game station for restaurant, virtual registration kiosk



Administration
Accounts
Development
Graphic
Import - Export
Logistics
Management
Production
Reception
Sales
« back

SAP AG, Walldorf, Germany

“friendlyway’s service was excellent. Our requirements were implemented seamlessly despite the tight timeframe—every feature worked perfectly. The system was very user-friendly, and the design of the terminals attracted many positive comments.”

friendlyway butler 17[®]



A Jack-of-All-Trades

In the field of easy access (barrier-free) kiosks, the friendlyway butler 17 has been setting new standards.

The height of this kiosk adapts to the user at the press of a button, making it ideally suited to medical centers, official buildings, and tourism hotspots.

Like all the other friendlyway terminals, the butler 17 features an enticing surface made of anodized aluminum or high-gloss lacquer. The multifunction front panel ensures a high level of component flexibility, and despite its compact housing, the friendlyway butler 17 has a powerful modern computer at its core.

The kiosk is available in two depth sizes to meet your individual technological requirements. For added installation flexibility, the friendlyway butler 17 can be supplied as a free-standing or wall-mounted kiosk.



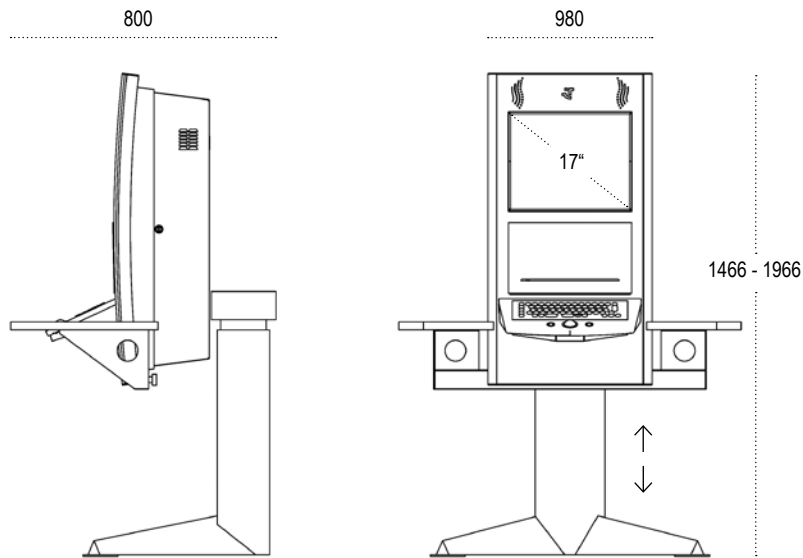

Technical Data

friendlyway butler 17

Specifications

- 17" (resolution: 1280 x 1024 pixels), 50 kg
- 980 * 1466 bis 1966 * 800 mm (width * height * depth), 80 kg
- Luminance: 300 cd/qm
- View angle: 160° / 160°
- Touch option: SAW, Surface Acoustic Wave
- CPU: Small Form Factor PC, Dell™ Optiplex™ 760 (or comparable performance)
- Housing: Anodized aluminum front panel, chrome-plated side panels, powder-coated metal rear panel. The terminal can be unlocked on the side and opened from the front. The stable hinge drive mechanism is suitable for rugged applications.
- Power supply: Internal 85 - 265 VAC
- Ambient temperature: +5°C - +35°C
- Location: Indoor

Highlights

- Unsurpassed design
- High-end construction
- Versatile
- Latest CPU technology
- Numerous configurations available
- Quick and simple integration of customer-specific hardware

Special Equipment

- Integrated hi-fi loudspeakers
- Touchscreen (normal or shock resistant)
- Keyboard (plastic or vandal-proof stainless steel)
- Magnetic strip and chip card reader
- Thermal printer (58 mm to DIN A4)
- Payment functions (coin and bank note verification)
- Wireless networking (WLAN)
- Telephone options (analog and VoIP)
- Webcam
- Barcode reader
- Foil label to personalize the kiosk with your corporate identity
- Heated system
- Further configuration options on request

Areas of Application

- Barrier-free access via electrical adjustment
- Individually adjustable for all users

Visitor welcome station, information Kiosk, virtual concierge solution, employee terminal, navigation system, game station for restaurant, virtual registration kiosk, museum (exhibition)



Versicherungskammer Bayern, Munich, Germany

“Our aim was to offer our employees centralized Internet access. With this, we also wanted the employees to engage more closely in the company’s Web presence. Both of these goals were achieved by installing the friendlyway Internet terminals. Our employees enjoy using the surf stations for browsing the net, and they use them frequently. We are also fully satisfied with friendlyway’s service.”

friendlyway d-sign 12[®]



Digital Designer Doorsign

The friendlyway d-sign product range integrates high-performance multimedia computers with elegant modern display technology.

The friendlyway d-sign 12 is a compact model that is especially suitable for digital room signs. Additionally, the small-scale display is easy to integrate into exhibition concepts; the friendlyway d-sign 12 features a fanless PC, so it can be mounted flush into walls.

The terminal is fully touch-screen capable, which is another advantage for trade-shows info presentations. Connecting the friendlyway d-sign 12 to your existing computer network is a quick and easy process.

A wide range of case options are available: The friendlyway d-sign 12 can be ordered with a frame made of glass, brass, copper, stainless steel, chrome, or wood.

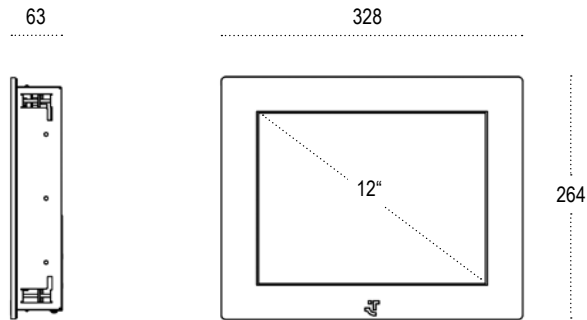

Technical Data

friendlyway d-sign 12

Specifications

- 12" (resolution: 800 x 600 pixels)
- 328 * 264 * 63 mm (width * height * depth), 10 kg
- View angle: 130° / 130°
- Luminance: 400 cd/qm
- Touch option: Resistiv 4 Wire
- CPU: Intel® Atom™ 1,6 GHz (270 N), 1 GB Ram, 160 GB HDD (or comparable performance)
- Housing: Anodized aluminum front panel, powder-coated metal shell
- Power supply: External 85 - 265 VAC
- Ambient temperature: +5°C - +35°C
- Location: Indoor, recessed wall mounting

Highlights

- High-end construction
- Unsurpassed design
- Reliable component assortment
- Versatile
- Latest CPU technology

Special Equipment

- Display frame also available in plexiglas or any RAL color
- Other configuration options available on request

Areas of Application

Interior signage / space management (Door Sign), Waiting room solution, Cueing System, Virtual Registration and reception kiosk, Trade fair, Retail store, Museum (Exhibition)

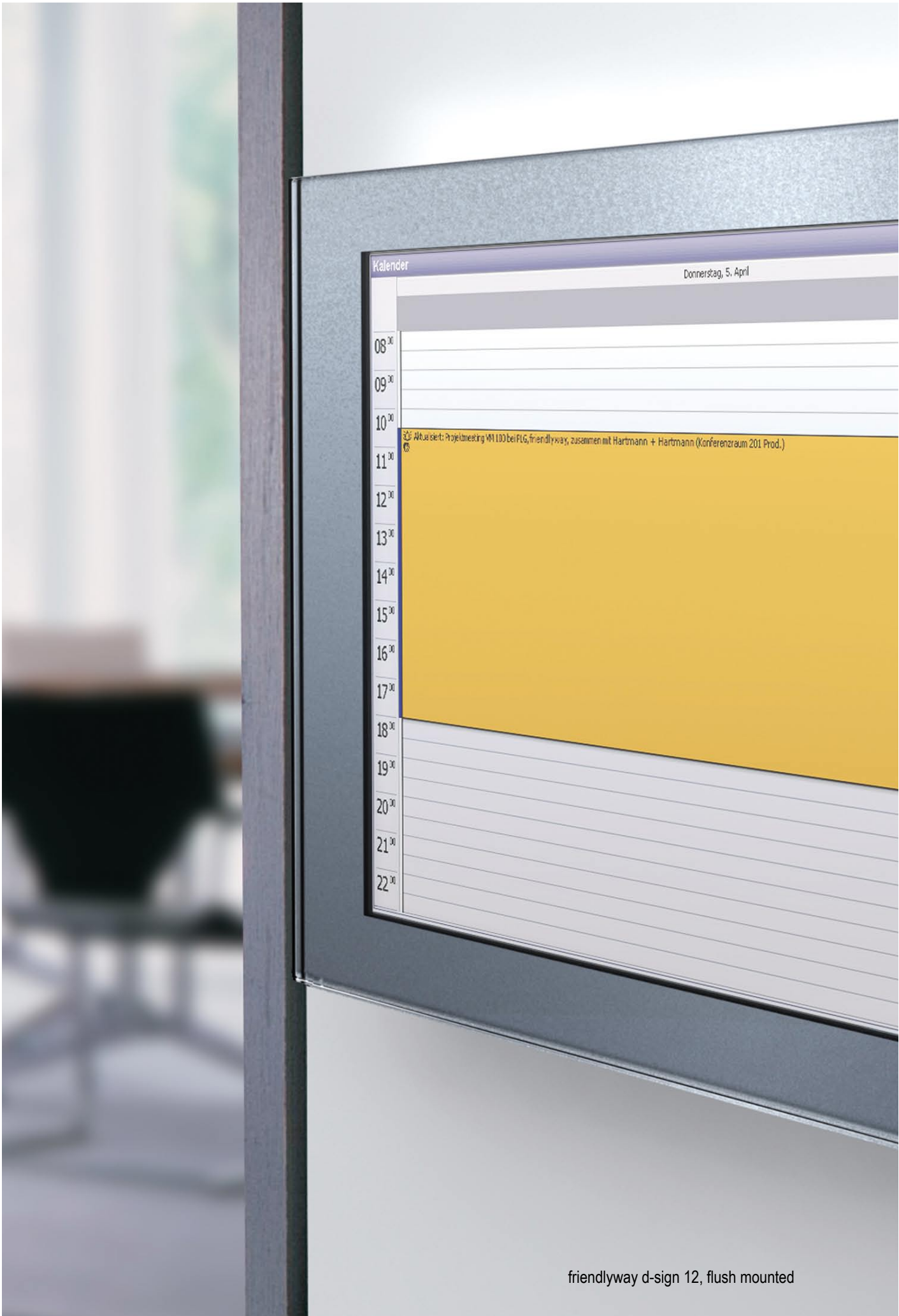

friendlyway d-sign 12, flush mounted

Glückauf GmbH, Lünen, Germany

“We compared a lot of terminal solutions, and in the end we opted for friendlyway. Only friendlyway manages to combine solid manufacturing quality and outstanding design with a wide range of technological options—all within a single product.”

friendlyway d-sign 32/40/52[®]



A Powerful Designer Display

The biggest of the friendlyway d-signs is an effective and eye-catching device for screening presentations, advertising films, and corporate TV.

The slim 4.7-cm side panels of the friendlyway d-sign 32/40/52 are complemented by strips of chrome. The anodized aluminum surface is scratchproof and fully enclosed, making the terminal particularly resistant to vandalism.

The shell of the friendlyway d-sign 32/40/52 contains a powerful multimedia computer. Thanks to the info terminal's modular layout, it can easily be extended with a touch screen and an audio system.

The friendlyway d-sign 32/40/52 can also be mounted on walls and ceilings, making it suitable for trade exhibitions and road shows.

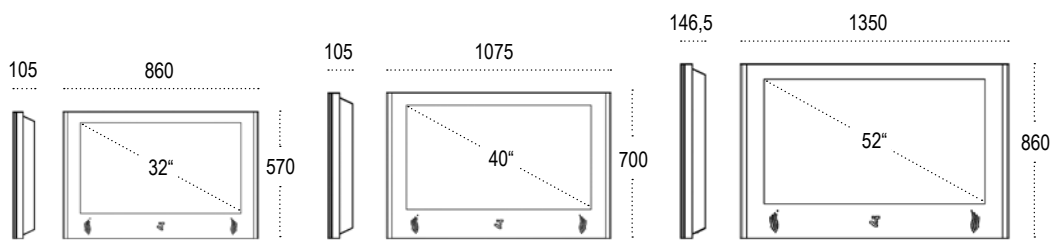

Technical Data

friendlyway d-sign 32/40/52

Specifications

- 32"** (resolution: 1360 x 768 pixels)
- 860 * 570 * 105 mm (width * height * depth), 37 kg
 - Luminance: 450 cd/qm
 - Touch option: SAW, Surface Acoustic Wave
- 40"** (resolution: 1920 x 1080 pixels)
- 1075 * 700 * 105 mm (width * height * depth), 45 kg
 - Luminance: 700 cd/qm
 - Touch option: SAW, Surface Acoustic Wave
- 52"** (resolution: 1920 x 1080 pixels)
- 1350 * 860 * 146,5 mm (width * height * depth), 80 kg
 - Luminance: 600 cd/qm
 - Touch option: Infrarot Touch, Multitouch
- View angle: 178° / 178°
 - CPU: Intel® GM965, Core™ Duo / Core™ 2 Duo Support (or comparable performance)
 - Housing: Anodized aluminum front panel, chrome-plated side panels, powder-coated metal rear panel
 - Power supply: Internal 85 - 265 VAC
 - Ambient temperature: +5°C - +35°C
 - Location: Indoor, wall-mount with optional bracket

Highlights

- Unsurpassed design
- High-end construction
- Versatile
- Reliable component assortment
- Latest CPU technology

Special Equipment

- Touch screen
- Integrated hi-fi loudspeakers
- Wall bracket
- Custom terminal color scheme in any RAL color
- Other configuration options available on request

Areas of Application

Interior signage / space management (Door Sign), Waiting room solution, Cueing System, Virtual Registration and reception kiosk



Willkommen bei der AGIS +++ Allianz Dresdner Informationssysteme GmbH

Die 3+Eins-Strategie der Allianz

Aktienkurs

Wir begrüßen Sie

- Hermann Denk (Allianz)
- Ingo Lehnert (Allianz)
- Uwe Maier (Allianz)
- Gerd Merkel (Allianz)

Willkommen bei der Allianz!



Willkommen bei der AGIS +++ Allianz Dresdner Informationssysteme GmbH

Museum of Modern Art, San Francisco, USA

„They (friendlyway systems) are gorgeous and will definitely pay for themselves within a year.“

friendlyway arctic 32[®]



A Rugged Field Worker

The friendlyway arctic 32 is designed specifically for outdoor deployment in urban public areas. Fully weather-proofed, it can be used as an info terminal, navigation guide, or ticketing system.

The terminal's elegant, understated design blends well into any urban setting. The high-performance computer technology at the core of the friendlyway arctic 32 has been designed with outdoor usage in mind. The electronics are well protected by a waterproof housing, which can optionally also feature temperature control and vandal-proofing. Every friendlyway arctic 32 terminal is fitted with a through-glass touch screen.

Operation, maintenance, and content updating is implemented through our proprietary software, which communicates with the friendlyway arctic 32 via the Internet, wireless technologies (GPRS, UMTS), and other up-to-date telecommunications methods. The software also facilitates simultaneous control of multiple terminals.



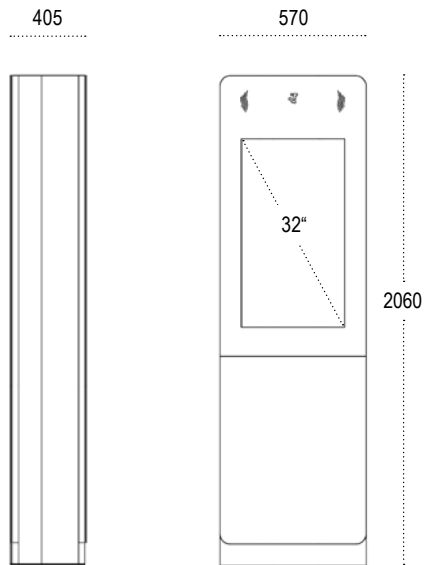

Technical Data

friendlyway arctic 32

Specifications

- 32" (resolution: 1360 x 768 pixels)
- 570 * 2060 * 405 mm (width * height * depth), 190 kg
- Luminance: 625 cd/qm (increased by solar radiation through Transflective Technology)
- View angle: 170° / 170°
- Touch option: Throughglass Touch Technology
- CPU: Intel® GM965, Core™ Duo / Core™ 2 Duo Support (or comparable performance)
- Housing: Glass Front 6mm safety glass, stainless steel shell with aluminum frame elements
- Power supply: Internal 230 VAC
- Ambient temperature: -20°C - +30°C vented, -20°C - +50°C air-conditioned
- Location: Outdoor

Highlights

- Designer shell for outdoor placement
- High-luminance transflective 32-inch display
- Through-glass touch screen with safety glass
- FSUE card (Watchdog)
- Heating element with user control
- Surge current limiter and line filter
- Powerful, up-to-date multimedia PC computer
- Ventilated cooling system
- Optional air conditioned systems available

Special Equipment

- 80 mm voucher printer
- Outdoor Webcam
- Full climate control
- Bluetooth adapter
- GSM surveillance module
- Outdoor Webcam
- Further configuration options on request

Areas of Application

Cities and public places, in front of historic buildings, Navigation system, Tourist information system



ΟΔΟΣ
ΙΩΣΗΦ ΣΗΦΑΚΑ
ΑΠΟ 12 → 2

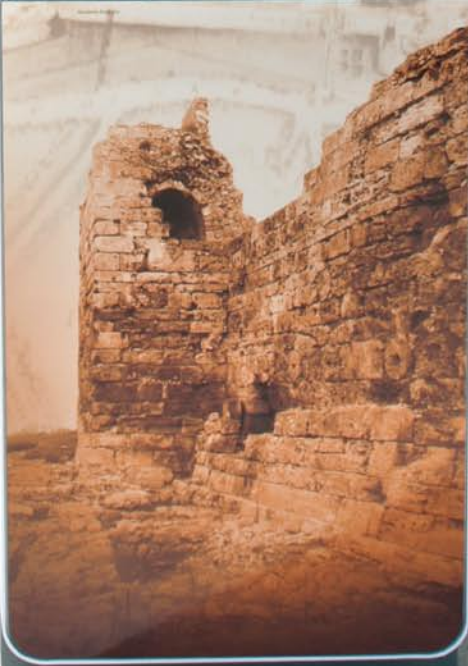

ΔΗΜΟΣ ΧΑΝΙΩΝ
ΔΗΜΟΤΙΚΑ ΕΡΓΑ

CNET Networks, Germany

“The friendlyway Internet browsing terminal is ideally suited to live presentations thanks to its user friendliness and professional design.”

friendlyway impress 32L[®]



A Charismatic Presenter

The friendlyway impress 32L is a superb medium for presenting advertising and business messages.

Thanks to the terminal's brilliant 32-inch display and integrated hi-fi loudspeakers, your information will command viewer attention at trade-shows and events, in your foyer, and even in your waiting rooms. Content can be switched on and off via a proximity sensor to further engage customer interest.

The anodized aluminum shell and slim outline of the friendlyway impress 32L provide an appealing and refined setting for your presentations. The terminal is very robust and stable, making it suitable for virtually any location.

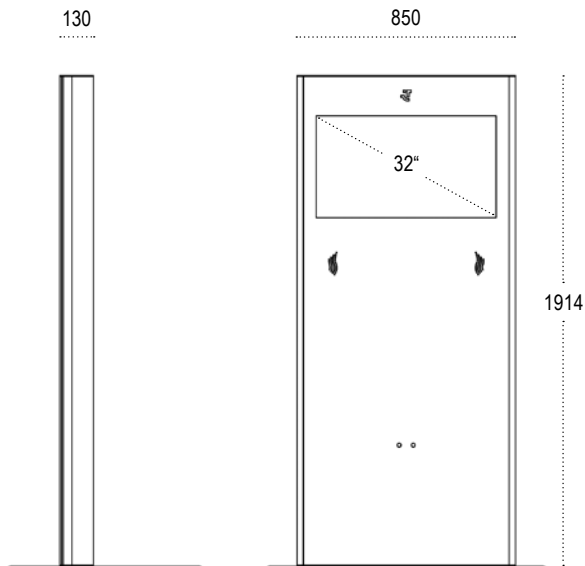

Technical Data

friendlyway impress 32L

Specifications

- 32" (resolution: 1360 x 768 pixels)
- 850 * 1914 * 130 mm (width * height * depth), 80 kg
- Luminance: 450 cd/qm
- View angle: 178° / 178°
- Touch option: SAW, Surface Acoustic Wave
- CPU: Small Form Factor PC, Dell™ Optiplex™ 760 (or comparable performance)
- Housing: Anodized aluminum front panel, chrome-plated side panels, powder-coated metal rear panel
- Power supply: Internal 85 - 265 VAC
- Ambient temperature: +5°C - +35°C
- Location: Indoor

Highlights

- Unsurpassed design
- High-end construction
- Versatile
- Reliable component assortment
- Latest CPU technology
- Numerous configurations available

Special Equipment

- Touch screen
- Webcam
- Ultrasonic proximity sensor
- Integrated hi-fi loudspeakers
- Terminal color scheme in any RAL color
- Foil label to personalize the kiosk with your corporate identity
- Wireless networking (WLAN)
- Telephone options (analog and VoIP)
- Further configuration options on request

Areas of Application

Visitor welcome station, Information Kiosks, Virtual concierge solution, Employee terminal, Navigation system, Game station for restaurant, Virtual registration kiosk

Ihre Auswahl:
BMW
3er
Preis 10.000-20.000 €
Schiebedach
Klima
Diesel

zurück

neue Suche

weiter

Automatik

Diesel

Klima

Navigation

Schiebedach

Leder

45 Treffer zeigen



BMW AG, Munich branch, Germany

“Meticulous, flexible, and reliable. This is the best way to describe the services provided by friendlyway. This is a partner for innovative solutions, one that we will certainly be calling on for future projects.”

friendlyway impress 40/52[®]



An Impressive Giant

The largest member of the friendlyway impress family wows customers and business partners alike with its gigantic 40-inch or even 52-inch upright display. On this elegant multimedia billboard, your messages are displayed sharply and concisely.

The displays of the friendlyway impress terminals are designed for maximum contrast and luminance, and they have a superb visibility range. Thanks to the built-in proximity sensor, visitors can be enticed with topical information as soon as they are in the unit's vicinity.

Like the smaller versions, the friendlyway impress 40/52 features a sophisticated anodized aluminum surface and an elegant shell design. The terminal is constructed for optimal mounting stability in virtually any location.

Like most of the friendlyway products, the friendlyway impress 40/52 has high-performance computer technology at its core.



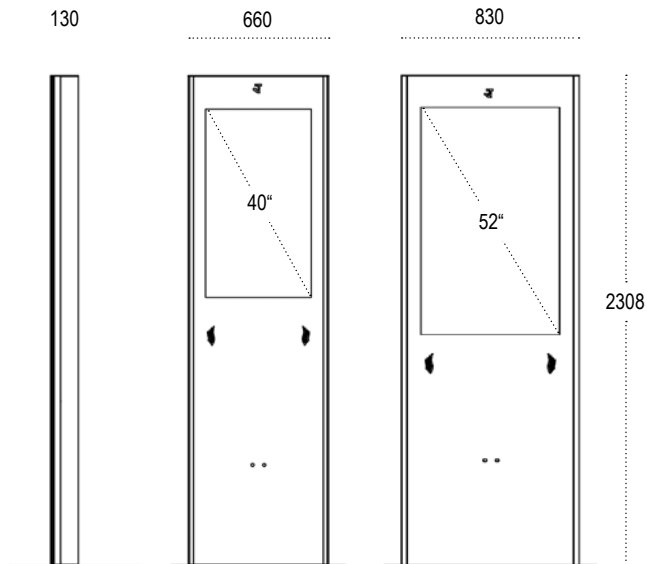

Technical Data

friendlyway impress 40/52

Specifications

- 40"** (resolution: 1920 x 1080 pixels)
- 660 * 2308 * 130 mm (width * height * depth), 80 kg
 - Luminance: 700 cd/qm
 - Touch option: SAW, Surface Acoustic Wave
 - CPU: Small Form Factor PC, Dell™ Optiplex 760 (or comparable performance)
- 52"** (resolution: 1920 x 1080 pixels)
- 830 * 2308 * 130 mm (width * height * depth), 110 kg
 - Luminance: 600 cd/qm
 - Touch option: Infrarot Touch, Multitouch
 - CPU: Intel® GM965, Core™ Duo / Core™ 2 Duo Support (or comparable performance)
 - View angle: 178° / 178°
 - Housing: Anodized aluminum front panel, chrome-plated side panels, powder-coated metal rear panel
 - Power supply: Internal 85 - 265 VAC
 - Ambient temperature: +5°C - +35°C
 - Location: Indoor

Highlights

- Unsurpassed design
- High-end construction
- Versatile
- Latest CPU technology
- Numerous configurations available

Special Equipment

- Touch screen
- Webcam
- Ultrasonic proximity sensor
- Integrated hi-fi loudspeakers
- Terminal color scheme in any RAL color
- Foil label to personalize the kiosk with your corporate identity
- Wireless networking (WLAN)
- Telephone options (analog and VoIP)
- Further configuration options on request

Areas of Application

Visitor welcome station, Information kiosk, Virtual concierge solution, Employee terminal, Navigation system, Game station for restaurants, Virtual registration kiosk



Migros Switzerland, Zurich

“[...] the design of the [friendlyway] units is very popular and the Power Towers [friendlyway impress] attract attention and curiosity. From all age groups, male and female alike.”

friendlyway luminum 32/40[®]

A Luminous and Interactive Advertising Pillar

The friendlyway luminum 32/40 frames your information with subtle color and light effects to attract viewer attention. Your services will be identifiable even from long distances.

The elegant designer display panel of the friendlyway luminum 32/40 is complemented by a distinctive background lighting pillar, which can assume any color scheme—for example, the colors of your corporate identity. The anodized aluminum housing of the friendlyway luminum 32/40 is attractively slim at just 4.7 cm and has chrome-plated side panels.

The terminal is fitted with a generously sized 32-inch or 40-inch display with an extra-wide viewing angle. As a standalone solution, the friendlyway luminum 32/40 is ideally suited for deployment at trade-shows.

The friendlyway luminum 32/40 is fitted with an integrated high-performance computer, and it can also be connected externally to any standard multimedia PC. The modular layout of the terminal is designed for maximum flexibility.



32" = 792
40" = 855

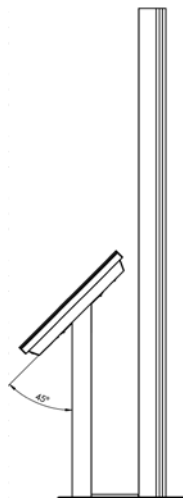

860

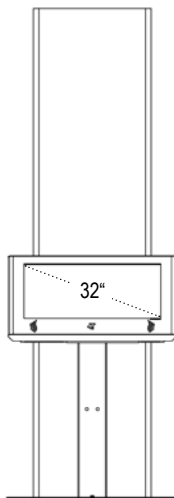

1075

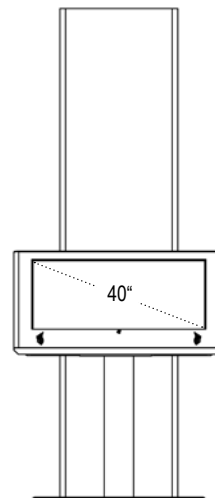

2517

Technical Data

friendlyway luminum 32/40

Specifications

- 32"** (resolution: 1360 x 768 pixels)
- 860 * 2516 * 792 mm (width * height * depth), 110 kg
 - Luminance: 450 cd/qm
- 40"** (resolution: 1920 x 1080 pixels)
- 1075 * 2516 * 855 mm (width * height * depth), 118 kg
 - Luminance: 700 cd/qm
 - View angle: 178° / 178°
 - Touch option: SAW, Surface Acoustic Wave
 - CPU: Intel® GM965, Core™ Duo / Core™ 2 Duo Support (or comparable performance)
 - Housing: Anodized aluminum front panel, chrome-plated side panels, powder-coated metal rear panel
 - Power supply: Internal 85 - 265 VAC
 - Ambient temperature: +5°C - +35°C
 - Location: Indoor

Highlights

- Unsurpassed design
- High-end construction
- Versatile
- Reliable component assortment
- Latest CPU technology

Special Equipment

- Touch screen
- Ultrasonic proximity sensor
- Integrated hi-fi loudspeakers
- Terminal color scheme in any RAL color
- Wireless networking (WLAN)
- Telephone options (analog and VoIP)
- Foil label to personalize the kiosk with your corporate identity
- Further configuration options on request

Areas of Application

Interior signage / space management (door sign), waiting room solution, cueing system, virtual registration and reception kiosk, trade fair, retail store, museum (exhibition)



SÜDWESTBANK AG, Stuttgart, Germany

“At this point I would like to thank friendlyway and its employees for their great work. We are very happy with our new reception solution, an innovative approach made possible by the friendlyway luminum. Our entrance area has benefited immensely from the installation of this virtual receptionist.”

Professional Line



friendlyway empire 19[®]



Elegance through Reduction

Reduction is a process that brings out the essentials. By eliminating everything unnecessary, we are emphasizing the minimalist design of the friendlyway empire 19. The kiosk's revolutionary double-layer shell contains nothing but the finest state-of-the-art technology. The 7-cm-slim housing presents a stunningly brilliant 19-inch display with full touch-screen capabilities.

The friendlyway empire 19 is the world's first floor-mounted kiosk system that doesn't rely on a separate computer case. In this system, the computer is integrated into the ultra-slim contours of the kiosk—without any unwieldy bulges or external boxes.

Featuring a rugged and particularly scratch-resistant surface, the empire 19 kiosk is a great new addition to our family of trusty info terminals, and it will never disappoint. Get in touch with us directly for a quote; the price may well surprise you!



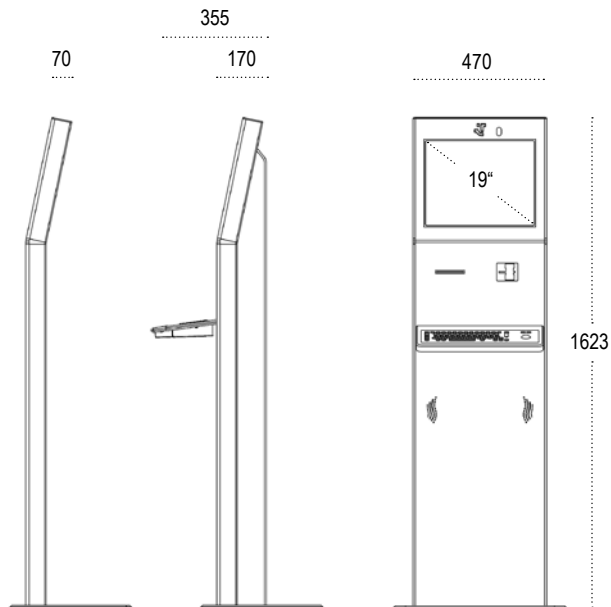

Technical Data

friendlyway empire 19

Specifications

- 19" (resolution: 1280 x 1024 pixels)
- slim: 470 * 1623 * 70 mm (width * height * depth), 40 kg
- large: 470 * 1623 * 170 mm (width * height * depth), 45 kg
- Luminance: 300 cd/qm
- View angle: 178° / 178°
- Touch option: SAW, Surface Acoustic Wave
- CPU: Small Form Factor PC, Dell™ Optiplex™ 760 (or comparable performance)
- Housing: Powder-coated metal
- Power supply: Internal 85 - 265 VAC
- Ambient temperature: +5°C - +35°C
- Location: Indoor

Highlights

- Unsurpassed design
- High-end construction
- Versatile
- Reliable component assortment
- Latest CPU technology
- Numerous configurations available

Special Equipment

- Powerful, up-to-date multimedia PC computer
- Integrated hi-fi loudspeakers
- Touch screen SAW
- Keyboard (plastic or vandal-proof stainless steel)
- Magnetic strip and chip card reader
- Thermal printer (58 mm to 112 mm and DIN A4)
- Webcam
- Ultrasonic proximity sensor
- Additional display above kiosk system (optional)
- Barcode reader, omni-directional
- Wireless networking (WLAN)
- Foil label to personalize the kiosk with your corporate identity
- Further configuration options on request

Areas of Application

Internet kiosk, visitor welcome station, virtual concierge solution, employee intranet terminals, navigation system, self-service kiosk, information kiosk, game station for restaurants, trade fair terminal, contact management system



Norisbank AG, Nuremberg, Germany

“It was quite an achievement in Germany to introduce a new sales format onto the market as quickly as we did. This wouldn't have been possible without friendlyway and friendlyway's dedicated employees!”

friendlyway empire 22D[®]



The third dimension of success

Never before in the history of friendlyway AG has a new product concept become a best-seller as fast as the friendlyway empire. The friendlyway empire clearly offers the perfect combination of design, quality, and low price.

Due to the high sales success of the friendlyway empire, we have decided to go the third dimension with this product. Its elegant and spacious casing provides enough room for transaction modules, various printing systems, and even a color laser printer.

With the help of a handle, the entire inner workings can be backed out of the anti-vandalism casing using the silent embedded push-action system. Servicing the friendlyway empire involves simply installing replacement modules.

The 56 cm 16:9 screen is extraordinarily large for a self-service system, and is thus very user-friendly, enabling applications to be operated with the touch of a finger.

Please get in touch with us directly for further details. We would be very happy to provide you with a quote for the friendlyway empire 22D.



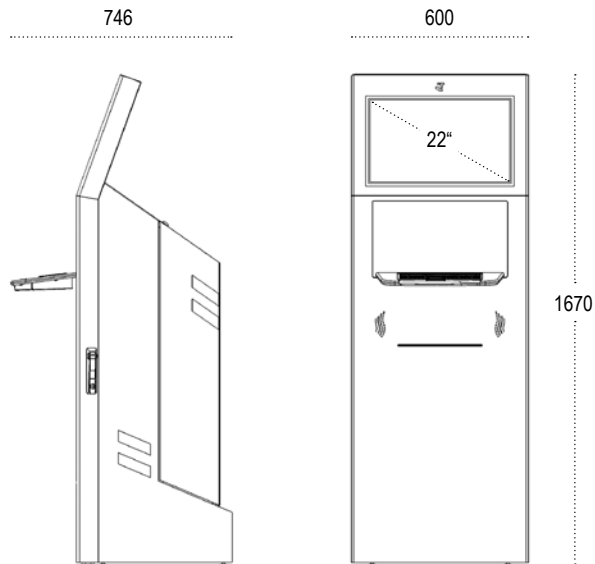

Technical Data

friendlyway empire 22D

Specifications

- 22" (resolution: 1680 x 1050 pixels)
- 600 * 1670 * 746 mm (width * height * depth), 80 kg
- Luminance: 300 cd/qm
- View angle: 160° / 160°
- Touch option: SAW, Surface Acoustic Wave
- CPU: Small Form Factor PC, Dell™ Optiplex™ 760 (or comparable performance), as well as mini Tower
- Housing: Powder-coated metal
- Power supply: Internal 85 - 265 VAC
- Ambient temperature: +5°C - +35°C
- Location: Indoor

Highlights

- Unsurpassed design
- High-end construction
- Versatile
- Reliable component assortment
- Latest CPU technology
- Numerous configurations available

Special Equipment

- Powerful, up-to-date multimedia PC computer
- Integrated hi-fi loudspeakers
- Touch screen SAW
- Keyboard (plastic or vandal-proof stainless steel)
- Magnetic strip and chip card reader
- Thermal printer (58 mm to 112 mm and DIN A4)
- Webcam
- Ultrasonic proximity sensor
- Additional display above kiosk system (optional)
- Barcode reader, omni-directional
- Wireless networking (WLAN)
- Foil label to personalize the kiosk with your corporate identity
- Further configuration options on request

Areas of Application

Internet kiosk, visitor welcome station, virtual concierge solution, employee intranet terminal, navigation system, self-service kiosk, information kiosk, game station for restaurants, trade fair terminal, contact management system

friendlyway welcome 32/40/52



An Elegant Reception Clerk

With the friendlyway welcome 32/40/52, you can welcome your visitors in perfect style. This digital sign will charm any guest with an eye for technological elegance.

The upright 32, 40 or 52-inch display is bright and attracts attention even over long distances. The display format makes the terminal particularly suitable for split screens. On-screen presentations can be triggered and shut down via a proximity sensor. Inside the terminal's shell, there is a powerful PC computer that ensures the flawless presentation of your content.

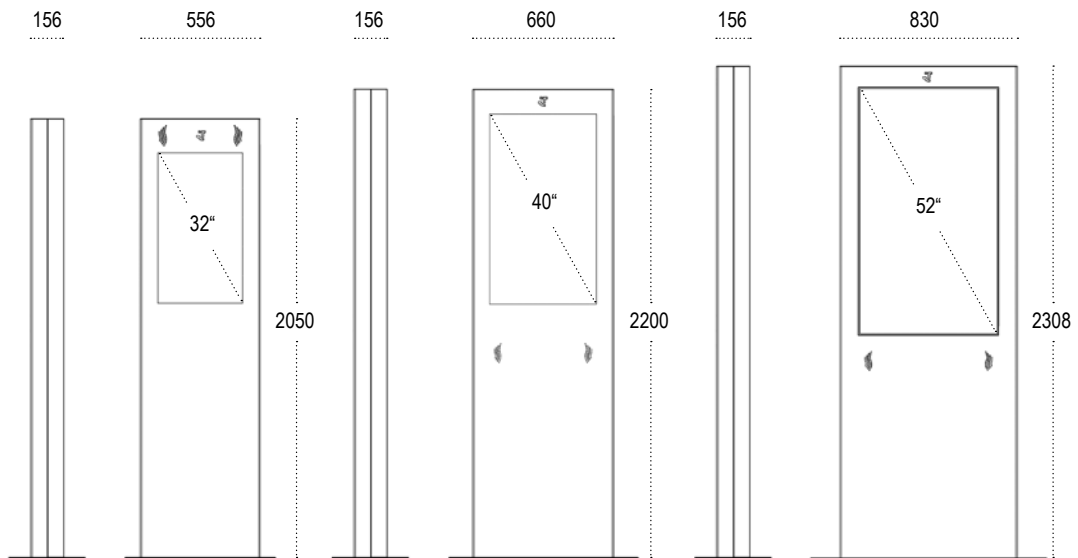

Technical Data

friendlyway welcome 32/40/52

Specifications

- 32" (resolution: 1360 x 768 pixels)
- 556 * 2050 * 156 mm (width * height * depth), 80 kg
- Luminance: 450 cd/qm
- Touch option: SAW, Surface Acoustic Wave
- 40" (resolution: 1920 x 1080 pixels)
- 660 * 2200 * 156 mm (width * height * depth), 95 kg
- Luminance: 450 cd/qm
- Touch option: SAW, Surface Acoustic Wave
- 52" (resolution: 1920 x 1080 pixels)
- 830 * 2308 * 156 mm (width * height * depth), 110 kg
- Luminance: 600 cd/qm
- Touch option: Infrarot Touch, Multitouch
- View angle: 178° / 178°
- CPU: Small Form Factor PC, Dell™ Optiplex™ 760 (or comparable performance)
- Housing: Steel, High Gloss Powder Coated
- Power supply: Internal 85 - 265 VAC
- Ambient temperature: +5°C - +35°C
- Location: Indoor

Highlights

- Unsurpassed design
- High-end construction
- Versatile
- Reliable component assortment
- Numerous configurations available

Special Equipment

- Touch screen (normal or impact resistant)
- Keyboard (plastic or vandal-proof stainless steel)
- Wireless networking (wireless LAN)
- Webcam
- Barcode reader
- Hybrid card reader
- Printer 56 mm and 80 mm
- Telephone options (analog and VoIP)
- Personalization to kiosk exterior with your corporate identity
- Other configuration options available on request

Areas of Application

Visitor welcome station, Information kiosk, virtual concierge solution, employee intranet terminal, navigation system, self-service kiosk, information kiosk, game stations for restaurant, trade fair terminal, contact management system

friendlyway porter 19



The Compact Kiosk Solution

With the friendlyway porter 19, you'll make a grand entry even in the smallest of spaces – perhaps in a storefront or a waiting room. The space-saving terminal mounts directly to the wall.

The friendlyway porter 19 enjoys all the advantages of a full-size friendlyway kiosk in a compact package. Its rugged construction offers protection from vandalism.

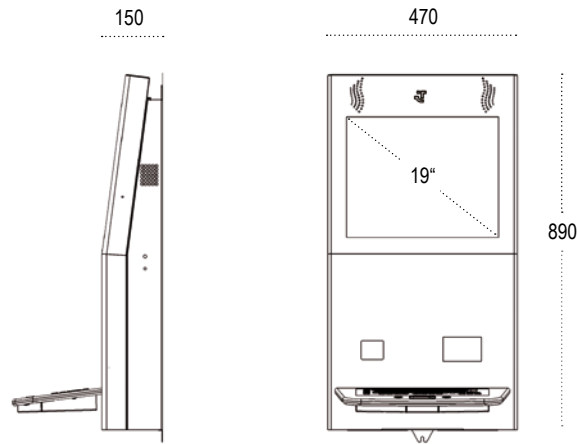

Technical Data

friendlyway porter 19

Specifications

- 19" (resolution: 1280 x 1024 pixels)
- 470 * 875 * 150 mm (width * height * depth), 40 kg
- Luminance: 300 cd/qm
- View angle: 178° / 178°
- Touch option: SAW, Surface Acoustic Wave
- CPU: Intel® GM965, Core™ Duo / Core™ TM 2 Duo Support Intel® Atom 1,6GHz (270N), (or comparable performance)
- Housing: Powder-coated metal
- Power supply: Internal 85-265 VAC
- Ambient temperature: +5°C - +35°C
- Location: Indoor

Highlights

- Unsurpassed design
- High-end construction
- Versatile
- Reliable component assortment
- Latest CPU technology
- Numerous configurations available

Special Equipment

- Touch screen (normal or impact resistant)
- Keyboard (plastic or vandal-proof stainless steel)
- Wireless networking (wireless LAN)
- Webcam
- Barcode reader
- Telephone options (analog and VoIP)
- Personalization to kiosk exterior with your corporate identity
- Other configuration options available on request

Areas of Application

Visitor welcome station, information kiosk, virtual concierge solution, employee terminal, navigation system, game station for restaurant, contact management system

friendlyway a-sign 12[®]



A high-end product

The friendlyway a-sign 12 is primarily designed for use as a shelf terminal. Elegant and reliable, the terminal advises your customers right next to the product and can be easily installed on any shelf with minimal space requirements.

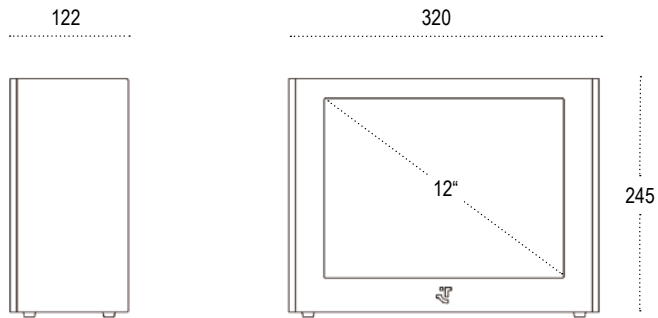

Technical Data

friendlyway a-sign 12

Specifications

- **12"** (resolution: 800 x 600 pixels)
- 320 * 240 * 122 mm (width * height * depth), 8 kg
- Luminance: 400 cd/qm
- View angle: 130° / 110°
- Touch option: Resistive 4 Wire
- CPU: Via Eden[®], 1Ghz, 1GB RAM, 160GB HDD (or comparable performance)
- Housing: Powder-coated metal
- Power supply: Internal 85 - 265 VAC
- Ambient temperature: +5°C - +35°C
- Location: Indoor

Highlights

- High-end construction
- Classic design
- Reliable component assortment
- Easy installation

Areas of Application

Product consulting directly at product placement, interior signage / space management, waiting room solution, cueing system, virtual registration and reception solution

friendlyway a-sign 32



The high-performance, designer monitor

The large friendlyway a-sign 32 brings your presentations, advertisements or corporate TV to center stage directly to the public. A high-performance multimedia PC is integrated in the housing of the friendlyway a-sign 32.

Specially designed for trade fair and road show applications, the terminal allows trouble-free wall mounting.

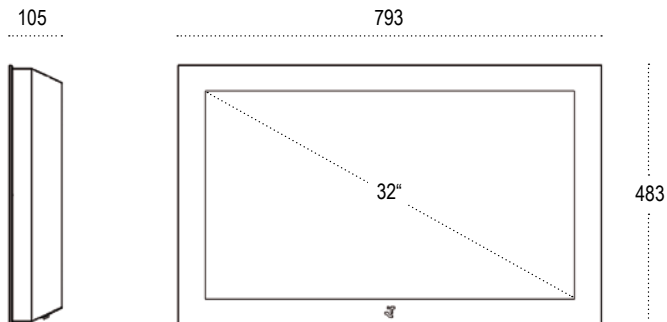

Technische Daten

friendlyway a-sign 32

Specifications

- 32"** (resolution: 1360 x 768 pixels)
- 795 * 490 * 100 mm (width * height * depth), 30 kg
 - Luminance: 450 cd/qm
 - View angle: 178° / 178°
 - Touch option: SAW, Surface Acoustic Wave
 - CPU: Intel® GM965, Core™ Duo / Core™ 2 Duo Support (or comparable performance)
 - Housing: Plexiglas front, powder-coated metal rear panel
 - Power supply: Internal 85 - 265 VAC
 - Ambient temperature: +5°C - +35°C
 - Location: Indoor, wall-mount with optional bracket

Highlights

- Unsurpassed design
- High-end construction
- Versatile
- Reliable component assortment
- Latest CPU technology

Special Equipment

- Touch screen
- Wall bracket
- Custom terminal color scheme in any RAL color
- Other configuration options available on request

Areas of Application

Interior signage / space management, waiting room, cueing system, virtual registration and reception solution, trade fairs, retail store, museum (exhibition)

Software



friendlyway composer 9[®]

friendlyway composer 9 and friendlyway composer network services is an all-in-one software product which generates and manages multimedia and digital signage content for kiosks and public displays. The usage of popular file formats and enhanced usability allows an organization to implement modern displays technologies easy and quickly without additional IT and personnel effort.

friendlyway composer 9 covers requirements of a kiosk or display digital signage network, starting with easy content management and scheduling and ending with content distribution and monitoring of kiosks or player stations.

Key benefits of friendlyway composer 9

friendlyway composer 9 encapsulates support of varied media formats, animated content templates, management and scheduling of multimedia content, smooth playback of different media types on one display, one-click distribution and monitoring of content to kiosks or player stations.

Smallest effort and shortest learning curve

Owing to use of the most popular media formats and a very intuitive MS Office-like user interface, composer 9 requires significantly less IT, programming and designer efforts in comparison with competitors' software packages.



Best price/performance ratio on the market

Using media formats widely offered by media agencies and reasonable network features, friendlyway composer 9 offers the optimal price/performance choice for organizations with regional departments or stores, which contact media agencies for production of advertising and drive the digital signage network from the central office with a minimum number of employees required.

Best playback quality

friendlyway composer 9 is the only software package on the market which offers high quality of playback for many combinations of various file formats. This distinguishes us from many competitors, who have to reduce the number and combinations of supported formats to reach acceptable quality of playback.

Scalability of systems

friendlyway composer 9 is scalable from one-display system managed on demand from within notebook up to thousands of kiosks or displays connected to the central management server.

System requirements



composer workstation

Commercial available computer, Windows XP SP2 or SP3 or Windows Vista (no Home Editions), 1GB RAM, Graphics card with DirectX 9 support and min. 64 MB RAM, 100 free HDD space, network card.



player station

Commercial available computer, Windows XP SP2 or SP3 or Windows Vista (no Home Editions)*, 512MB RAM, Graphics card with DirectX 9 support and min. 64 MB RAM, 100 free HDD space, network card, TV card (optionally), multi head graphic card (optionally). * Windows XP Embedded version is available upon request on certified hardware. (It is recommended to use Windows Embedded Standard 2009).



Network services server

Up to 10 players – Windows XP SP2 or SP3, 1 GB RAM, network card, 10 GB free space. **More than 10 players** – Windows 2003 or 2008 Server Standard Edition, 2 GB RAM, 100 GB free space, 1Gbit network card

friendlyway composer 9 installation scenarios



Mobile

friendlyway composer 9 and network service server will be installed on a notebook. Content deployment and monitoring will be available as soon the notebook is connected to the same network, where kiosks or players are placed. After distribution of content is finished, the notebook can be removed from the network without affect the player stations.



Office

friendlyway friendlyway composer 9 and network service server will be installed on an office computer. Content deployment and monitoring will be available as soon the computer is turned on. If the computer is turned off, the player will continue to playback the content.



Corporate

A network service server will be installed on the server inside the corporate network. Content deployment and monitoring of player stations are constantly available for the player stations connected to the same network.



Hosted

A network service server will be installed by the hosting provider as server housing or dedicated hosting. Content deployment and monitoring of player stations are constantly available for the player stations connected to the Internet.

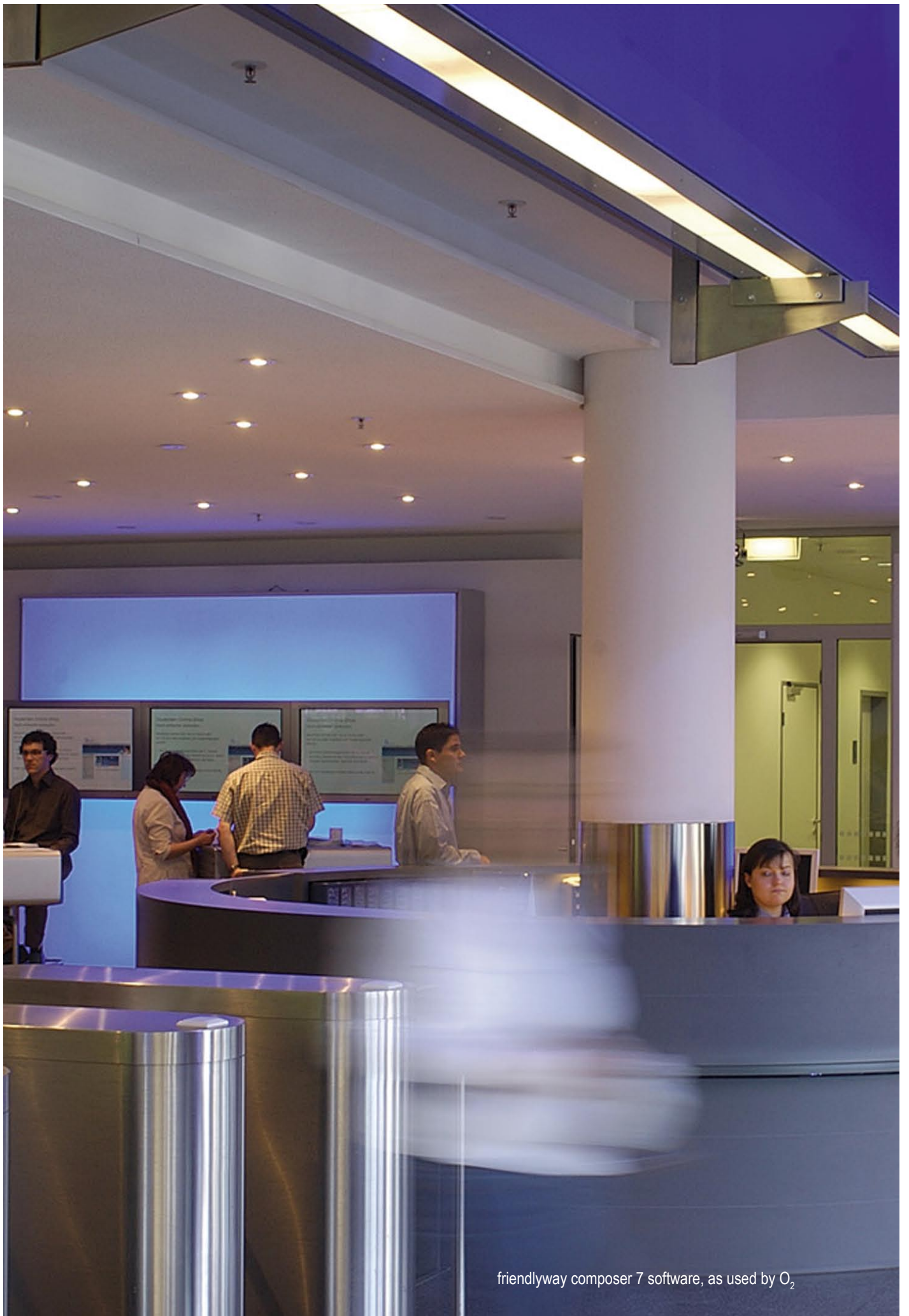

friendlyway composer 7 software, as used by O₂

O₂, Germany

“friendlyway has greatly simplified the centralized control of presentations. Employees and users alike are given immediate and easy access to the required information. This is a real time saver.”

composer 9[®] Features



Medien Formate

- **Pictures** – all picture formats, including formats with transparent background and animated picture formats
- **Videos** – playback of WMV, MPEG1, MPEG2, DIVX, MPEG4, MOV videos as well as streaming and HD videos
- **Microsoft PowerPoint** – Support of Microsoft PowerPoint presentations created with 2000-2007 versions of Microsoft PowerPoint. The player is able to playback multiple PowerPoint presentations simultaneously
- **Adobe Flash** – support of Flash animations with transparent background and online placed Flash files
- **Adobe PDF** – PDF documents are scrolled automatically based on a schedule
- **RSS and Text** – texts and RSS feeds are supported as slider or ticker. Tickers can be designed using different fonts as well as pictures. Tickers are able to run over video background
- **Web** – certain web page regions can be selected and dynamically displayed on the screens
- **TV** – analog and digital (DVB-T/ DVB-S/ DVB-C) television. The precondition is that a TV card is installed on the kiosk or player station



Templates

- **Animated templates** – animated customer specific templates with customer logos and colors can be created from the Adobe Flash files by a friendlyway reseller or a local media agency
- **Template albums** – the customer has an ability to attach different templates per drag-n-drop from multiple template albums attached to the software. The template album for organization can be delivered by a reseller, a media agency or by designers inside the organization



Creation of online content and playlists

- **Creation of spots using content templates** – animated broadcast quality advertising spots can be easily created in the web browser from a library of content templates, pictures and texts.
- **Flexible playlist management** – playlist of spots can be easily defined by a simple sequence or a date range. Users have the ability to remove the spots from the playback quickly
- **Intelligent synchronization with player stations** – spots will be preloaded to player stations and constantly synchronized as soon as the online connection to the spot server is available



Content management and scheduling

- **Modern and user friendly interface** – the user interface significantly reduces the learning curve using Microsoft guidelines
- **Flexible display settings** – possibility to select display settings based on the aspect ratio or resolution of the target display. The content will be scaled to full screen automatically
- **Support of multiple displays** – software supports multiple displays with different content controlled with double or quad head graphics card or display wall controller
- **Timeline** – display time of media objects is indicated as a chart and can be easily customized using the mouse
- **Dynamic sequences** – software mixes the playlists automatically using repeat rate and time ranges during which the spots should be displayed
- **Scheduler** – content sequences can be assigned to certain day times or special events via calendar like in Microsoft Outlook
- **Media search service** – search service for the media on the DVD or in the corporate network.
- **Backgrounds** – it is possible to use colors, color transitions or pictures as a background
- **Background sound** – music or audio effects can be assigned to separate media elements
- **Visual effects** – it is possible to assign sliding or fading effects to whole pages or separate media objects



Playback

- **Performance** – a special technology cares for seamless playback of media objects without visual and loading effects
- **24x7 operation** – the player software has been developed to ensure 24x7 playback



Distribution and monitoring

- **Web based interface** – the player network can be controlled and monitored from the administration web console without further installation of software
- **Player monitoring** – kiosk and player stations are monitored around the clock. In case of failure, the playback starts immediately again. The information about the actual failures is sent to the service person per e-mail or SMS
- **Visual control** – screenshots from displays are sent live to the server and are available for visual control
- **Intelligent content distribution** – media projects are transferred incrementally with a reference to the download and validity time directly to kiosks or player stations
- **Automatic software updates** – software updates are transmitted and installed on kiosks or player stations automatically

composer 9[®] editions



Single Edition

composer will be installed by single edition directly on the computer equipped with a display on which digital signage must be displayed. To edit content, the user has to stop the playback and edit presentation directly on the display. This licensing model is ideal for single display installations.

Basic Edition

Basic edition supports creation of digital signage content on a workstation or a notebook, where players have own computers. Content update can be done by removable media or simple network share. This licensing model is most suitable for 1-3 displays not connected to the network or if content updates on the player stations are not intensive.

Enterprise-Lizenz

Enterprise license provides all software functions without limitation and is available for a large digital signage networks upon request. This type of licensing is most suitable for networks with more than 100 players.

Professional Edition

Professional edition enables additional features of the software and can manage multiple displays directly from the composer user interface. Content updates will be maintained by network services, which can be installed on the same computer as the composer or on a separate server. The player stations will require additional network services license to be connected to the network services.

Features Matrix

	Single Edition	Basic Edition	Professional Edition
Media Formats			
Picture	+	+	+
Video	+	+	+
PowerPoint	+	+	+
Flash	+	+	+
Text and RSS	+	+	+
@caster Object	+	+	+
PDF	-	-	+
Web	-	-	+
TV	-	-	+
Embedded projects	-	-	+
Content Management			
Modern user interface	+	+	+
Flexible display settings	+	+	+
Support of multiple displays	+	+	+
Timeline	+	+	+
Media search service	+	+	+
Animated templates	+	+	+
Template album	+	+	+
Backgrounds	+	+	+
Background sound	+	+	+
Visual effects	+	+	+
24x7 playback	+	+	+
Easy development via USB or CD-ROM	+	+	+
Scheduler	-	-	+
Dynamic sequence	-	-	+
Upgrade ability to next version	-	+	+
Max pages and sequences (page/sequence)	3/1	3/1	ulimited
Max kiosks or players	1	3	ulimited
Max users	1	1	ulimited
Network features			
Web based management console	-	-	+
Player monitoring	-	-	+
Visual control of displays	-	-	+
Intelligent content distribution	-	-	+

Content Vorlagen

Advertising spots in digital signage requires broadband visual quality and should be animated to catch the attention of the audience. The creation of high-quality content usually requires designer and animation developer skills.

friendlyway composer 9 offers a content template technology which allows the users to easily change the texts and pictures inside of high-quality templates, created by professional media agencies.

friendlyway software offers two ways to create spots from templates quickly, which are online creation of spots and playlists using friendlyway @caster or creation of spots using template albums directly in friendlyway composer 9.

Creation of advertising spots using friendlyway composer 9

Content templates can be used to create content spots directly in the friendlyway composer installed on the user workstation. The templates will be attached to the composer software as content albums containing the templates, specially created by local media agencies.

As the spots are created directly in the friendlyway composer, they can be combined with other media objects like videos, text crawlers etc. to create media-rich digital signage content.



Creation of advertising spots and management of playlists using friendlyway @caster

friendlyway @caster is an online application which allows creating playlists of spots from content templates and managing playlists. In case friendlyway @caster is used to create spots, it is not necessary to install friendlyway composer 9 on the workstation. It is enough to access the server, where the spot server is hosted from the web browser which has an internet or intranet connection.

This scenario is perfectly suitable for local departments or small businesses, which want to insert own local content spots in between of running composer presentation or create simple dynamic playlists from the available content templates.

Advertising spots created by friendlyway @caster will be automatically loaded by friendlyway player and used for playback. The player does not require permanent connection to the spot server as the spots will be preloaded locally during the time the connection is available.

Interactive Applications



friendlyway secure browser

friendlyway secure browser is a kiosk web browser specially designed to allow the internet access to run your interactive web applications on kiosks installed in the public area.

Built on top of Microsoft Internet Explorer, friendlyway secure browser enables all modern web technologies on your kiosks like simple or complex web pages, script and multimedia, as well as customized navigation buttons and user defined appearance.



friendlyway secure browser Features

- **Full featured web browser** – friendlyway secure browser is built using Microsoft Internet Explorer and supports all rendering features of the Internet Explorer
- **Desktop Protection** – friendlyway secure browser prevents users from unauthorized access to operating system objects

- **User defined appearance** – friendlyway secure browser is able to display or hide browser elements like address bar, scrollbars, toolbars depending on the application needs.
- **Integration with digital signage** – the software allows splitting the screen with friendlyway player or using friendlyway player as full featured digital signage screen saver
- **Support for Adobe and Microsoft Office Documents** – the software offers robust and safe rendering of Adobe and Microsoft Office documents like PDF files, Microsoft Word, Microsoft Excel or Microsoft PowerPoint files without giving the user access to the file system



System requirements

Microsoft Windows XP SP2 or Vista, 32 Bit, 256 MB Memory, 10 MB disk space

Microsoft, Unterschleissheim, Germany

“[...] friendlyway’s professional security solution lets us collect feedback from running events via Tablet PC in real-time, without compromising our internal security standards. friendlyway secure browser not only saves us time and effort, it also improves our response time to customer feedback.”

Service



friendlyway Project Development

Single-Supplier Turnkey Solutions

friendlyway is a sought-after and competent partner for the realization of complex projects in the field of Self Service and Digital Signage. We provide consulting right from the planning stage, and we will gladly complete all the necessary implementation steps. Even during regular operation, we are available around the clock as a reliable support partner.

Our services include the planning and implementation of customized solutions, individually designed terminals, and display systems, and the programming of software specifically tailored to your local requirements.

The deployment possibilities are numerous: Point-of-sale communication, company communication, building automation—our experienced project managers can support you throughout.

You can also lease friendlyway systems. Contact us!





Project examples

THREE out of FOUR HUNDRED

Puma promotional campaign

- Integration of 12-inch displays into custom-made soccer models
- Programming of a promotion application for touch screens
- Support during the design stage and for project management

Electrolux

- Development of digital product information systems
- Programming of product search application (vacuum cleaner bags)
- Complete handling of roll out services in all German Metro C&C markets

BMW network.tv

- Development of the network.tv show using composer 9 software
- Worldwide distribution of content for different BMW dealerships
- Remote Management and Monitoring of network.tv stations

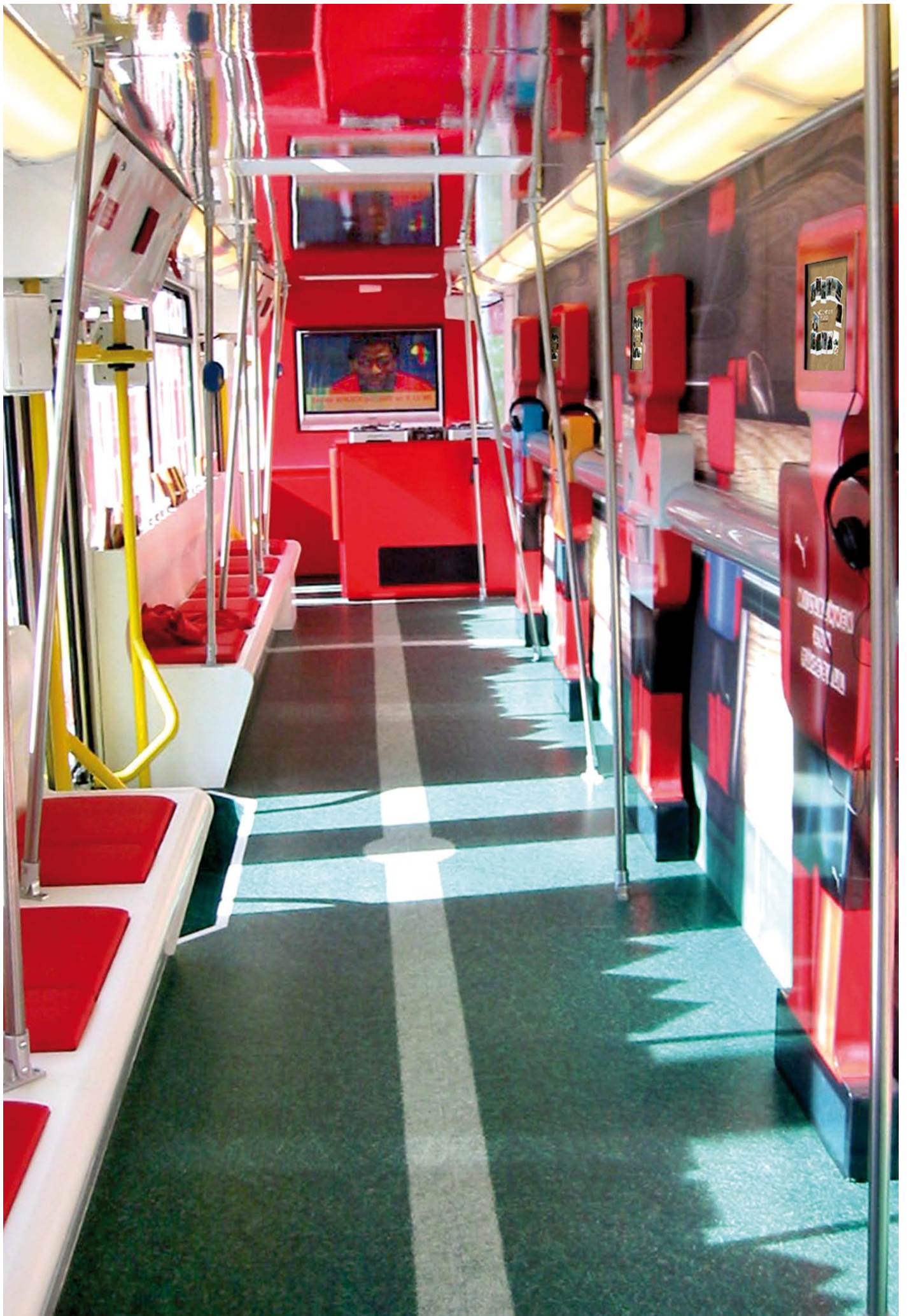

YAHOO!, Sunnyvale, USA

„We turned to friendlyway to help us extend the Yahoo! Branding. friendlyway’s kiosks are sleek in design, and very user friendly - we were impressed with how easy they made the entire kiosk process from beginning to end. friendlyway worked hard to make the kiosk ordering and delivery process as easy and stress-free as possible. We would definitely consider using friendlyway again.“

Traditional Services

As a manufacturer of Digital Signage and Self Service Systems, installed worldwide, friendlyway offers an entire line of valuable traditional services for partners and customers.

Maintenance Services

friendlyway stands behind its warranty, with tier one system components and general support services. friendlyway insures maximum availability of system components and software applications. Through stringent selection of system components, friendlyway guarantees the delivery of quality products with extremely low failure rates.

Start-up & Installation

Thanks to an internationally active partner network, installation and start-up services for friendlyway systems are widely available. During a start-up or installation service, a professional technician will get your terminal or display system up and running on the spot. The friendlyway support team can also provide support for the installation of friendlyway composer software easily over the telephone or via remote access. friendlyway can optimize your existing infrastructure to deliver you the best solution.

Support Helpdesk

The friendlyway Support Team, in cooperation with our Systems and Software experts, provides quick and convenient assistance via email, telephone or via remote access directly on your system.



Local Service

Technicians from friendlyway's extensive partner network are available locally to replace parts and or restore software. friendlyway offers maintenance contracts to provide you with excellent customer service and support.

Professional Services

friendlyway also has an extensive range of globally available professional services to fully serve your system needs.

Digital Signage & Self Service Consulting

Many factors must be considered in launching a successful Digital Signage or Self Service project. In addition to the correct component and software selection, implementation and service must be thoroughly planned out. friendlyway has acquired worldwide experience through the planning and implementation of hundreds of projects. In fact, our global experience and consulting services can help you successfully implement your projects.



Client-specific Solutions

friendlyway is your partner for unique, client-specific projects. An experienced team based in Munich is available to deliver solutions tailored to your individual projects. friendlyway is a global leader specializing in solutions exactly matched to customer requirements.

Training for Systems and Software

friendlyway offers training in several ways to suit your needs. We offer internet-based training, that presents important aspects of Digital Signage software via webinars. Also, our specially skilled software trainers can conveniently perform training sessions on location. Training on location is especially recommended for widely distributed user groups and business critical software applications. Additionally, for quick assistance, the systems can also be explained in detail by partner and client technicians on location or in Munich.

Digital Communication as a Service

The totally carefree package:
Digital Communication as a Service

Self service and digital signage projects consist of a variety of important elements. Often the mistake is made to distribute these elements to different parties or to internal resources that are not familiar with the subject.

friendlyway offers a solution from one source!

DCaaS means a care-free package with all the important components of a Self Service or Digital Signage project.

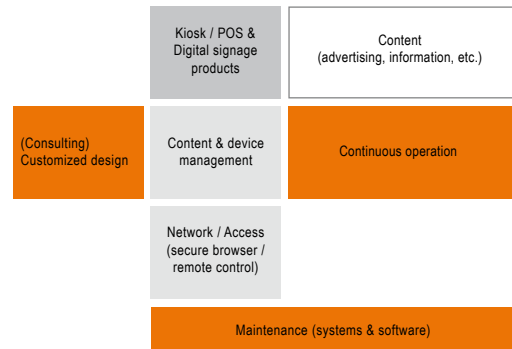

All elements means

- **Systems** - in the form of display or kiosk systems
- **Software** - Digital signage or interactive application software
- **Services** - Content und update management, monitoring & on site services, on request:
- **Financing**

Also project management, consulting, roll out services are included in one DCaaS project. The total services are transparently invoiced in the form of a monthly fee.

The Advantages of DCaaS are obvious

- Convenient monthly payments without overwhelming start-up costs
- Clearly-defined responsibilities
- Coherent, user-friendly plan
- No additional company or third party resources required
- In order to ensure a permanently successful project, the system is guaranteed by a „Service Level Agreement“

friendlyway sales staff works together with the client to develop a unique and suitable DCaaS strategy.

friendlyway Partners



Solution partners are using friendlyway products from the Digital Signage and Kiosk family to create high value solutions for the customers and to ensure optimum customer support. Experienced solution partners bear the seal „friendlyway Certified Partner“. Thus, friendlyway ensures that the user can draw on such

partners if needed, who have proven expertise in consulting and implementing solutions in Digital Signage and in the kiosk market. Prerequisite to become one of these partners is a high degree of experience with friendlyway products.

Electrolux, Nuremberg, Germany

„With the assistance of friendlyway’s solution, we provide the customer with a modern and very convenient alternative to search for his desired product. This ability gives us a market advantage in the customers’ eyes and over the competition right where we need it: directly on the shelf right at the purchase decision.“

Company





Made in Germany

From glockenspiels to hi-tech mobile displays: A behind-the-scenes look at friendlyway's road to success



Our navigation system is stumped and says “Off Road.” Now we know we’re not the only ones to lose our bearings after the traffic detour. Our journey to the birthplace of all friendlyway systems has suddenly taken us from Lower Bavaria to Canada, or at least that’s what it looks like. There’s nothing but wilderness as far as the eye can see. With its gentle forests, this mountainous landscape has probably been the inspiration for many a model railroad layout.

We stop in the next village and ask for directions. “Go up to the traffic circle, take your first right, then go straight up the mountain.”

The locals are friendly and helpful, and everyone knows our factory in the Bavarian Forest. The success of this region’s largest employer is very important for the well-being of the people here. The manufacturing company has been cultivating the art of precision mechanics for almost a century. Many employees have parents who worked here and today almost everyone at the company has been working there for twenty years or more. Continuity, reliability, and a tradition of high quality are core values. The company built the famous glockenspiel at the Munich’s New City Hall on Marienplatz. That was over a century ago, and it still chimes every day.

Tradition and Modernity

Metal is still being processed in Grafenau. But instead of mechanical clocks, the facility is now manufacturing friendlyway’s world-class hi-tech products. For almost ten years, friendlyway has enjoyed a successful partnership with its production partners in the Bavarian Forest. The partners have gone through ups and downs together. When the IT sector collapsed in 2001, the company faced huge challenges. It took advantage of the relatively quiet period to invest in product development, expand its product range, and modern-

Top: Harmony goes beyond the Zen garden, bottom: friendlyway impress during the “burn-in test”

ize production. Looking back, the company actually came out of the crisis stronger than ever.

For the past six years, the company has been consistently moving in one direction: toward the top.

“Right now, our biggest challenge is to achieve strong growth while ensuring that quality does not deteriorate,” says Mr. Grünzinger, head of the friendlyway production team. “Producing friendlyway systems requires extreme precision and care,” he explains. “The more precisely we assemble our components, the longer the life-span of every friendlyway product,” says the Bavarian native.

The production halls are meticulously clean and feature cutting-edge robotized welding systems. Suspended from the ceiling on automatic transport rails, friendlyway components silently float from one production step to the next. Employees wearing white gloves use magnifying glasses and precision rulers to check the metal parts for the most miniscule deviations. With standards like these, the company could even serve the aviation industry. Production Management digitally plans the DIN ISO 9001/9002-certified production processes and monitors them



Living the friendlyway

closely. It takes decades of experience and a highly trained team to manage these complex processes. Even then, they must be continually reviewed and improved.

“Our brand-new cutting-edge punching machine cost us over a half a million euros. Now we can trim friendlyway system components to tiny fractions of a millimeter,” says an enthusiastic Dr. Karl-Martin Glas, Chief Executive of the friendlyway production partner. The former quantum physics researcher from the famous CERN physics lab smiles at our question and goes on to say: “We may be the only company in the kiosk and digital signage sector with such standards of perfection.”

Efficiency and Automation

“The fact that we manufacture our products in Bavaria is all the more reason not to fear competition from Asia,” says Klaus Trox, Chief Executive of friendlyway AG. “You simply can’t beat our quality standards, outstanding flexibility, and rapid delivery times thanks to our close proximity to customers. Almost half the friendlyway systems we deliver have been tailored to meet individual customer requirements. A production facility in Asia wouldn’t be able to do that,” he says emphatically. “Thanks to our outstanding efficiency and automation, high German labor costs are not much of a problem.”

The co-founder of friendlyway AG knows what he’s talking about. After



Quality begins in the details

years of optimization, most processes at the friendlyway headquarters in Munich have been automated. A small team is in charge of the some 400 inquiries that reach the company from around the world each month. These queries travel directly from the friendlyway Web site to a native customer retention system, which is fully Web-based.

“In a matter of seconds, the new customer contact can be assessed and stored in our database. Today, it only takes a few minutes to create a professional quotation,” says Klaus Trox with satisfaction. “Five years ago, it took over a half an hour.” When a customer orders a friendlyway product, an electronic order confirmation is sent by the same system. Later, brief e-mails keep the customer informed of the production and shipping status. This, too, could well be a completely new function in this sector.

Production partners are also electronically integrated into this process. The customer’s order is converted into a production and procurement order in friendlyway’s enterprise resource planning system and sent to the partner. Components can then be delivered to the final assembly department based on this order. After the chassis and electronic components are connected in a process called a “marriage” in the automotive industry, Grafenau sends a confirmation message to Munich. “That way we can keep up to date on the production status of friendlyway systems ordered,” says Christoph Müller, who is in charge of such areas as Production Control and Purchasing at friendlyway.

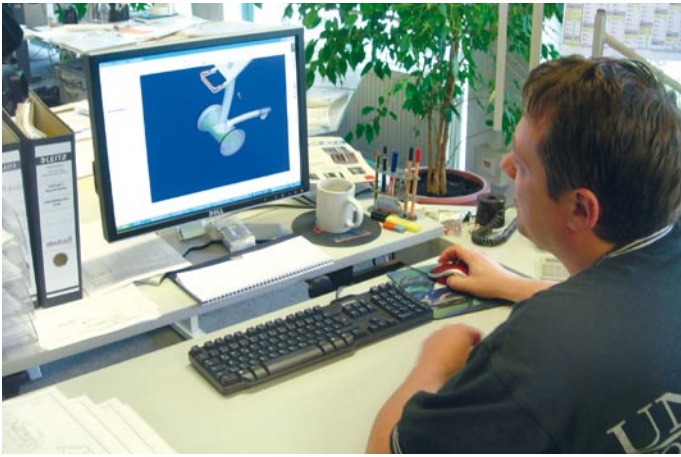

“This process is actually quite similar to the process for developing new automobiles,” says the Executive Board member in charge of system development at friendlyway, Klaus Trox, recalling his long career at Kontron, a former subsidiary of BMW. “The only difference is that in our sector we have to deal with even shorter innovation cycles.” Collaboration with production partners is now a firmly established practice in the automotive industry. For example, BMW has contracted Magna Steyr, an Austrian manufacturer, to build its X3 sport utility vehicle.

While the first functional prototype is being developed, the friendlyway marketing department begins advertising the product. At the same time, the friendlyway sales team creates a waiting list for the first preorders. During the phase before serial production, deliveries can take up to twelve weeks. Once batch production starts, average delivery times are reduced to two to three weeks. This could very well be the world’s fastest turnaround time for an on-demand production facility.

friendlyway’s research and development team has always placed top priority on increasing the value and usefulness of friendlyway products. As a result, it has defied the trends in the computer industry and kept sales prices nearly constant over the past ten years—even more stable than the price of gold during this period.

“It’s important for us to offer friendlyway customers more for their investment than our competitors,” says Mathias Freund, head of systems development at friendlyway. “That’s why we’ve always done all we could to improve friendlyway products on a continual basis.” Time and again, competitors have tried to gain an edge on the market with low-cost products. After a couple of bankruptcies, a provider will try to win over customers through cheap prices instead of product quality. “Over the years, we’ve seen companies like that disappear as quickly as they appeared,” recalls Mathias Freund, “but so far, customers have always chosen quality over low prices.”

“For example, only the highest quality and most durable industrial displays are used in friendlyway systems. These displays are more expensive from a purchasing perspective, but in the long run customers will enjoy their friendlyway products much more as a result. As another example, the friendlyway classic systems are 4.7 cm wide, making them the world’s slimmest kiosk systems. That’s because we decided to put the screen electronics below the screen and not behind it. It would have actually been cheaper to manufacture electronics that go behind the screen, but that would have destroyed the system’s highly elegant side profile,” explains Mathias Freund.

The vandal-proof friendlyway keyboard is made of metal and also features an optical trackball, which is integrated into the keyboard system so that users can control the system as they would with a mouse. Its optical sensor makes the trackball extremely resistant to wear and almost fail-proof. Although the keyboard is more expensive to purchase, it is actually a more economical solution to operate because there are no extra costs for repairs needed due to mechanical breakdowns.



Top: 3D CAD development, bottom: The challenge of logistics

Research and Development

“In the past ten years, we’ve invested over ten million euros in the development of our hardware and software products,” says Klaus Trox. As a result, the company has worked with partners to make improvements such as substantially reducing development cycles for new products. Whereas in the past it took at least nine months to develop a new display system, today product development takes less than twelve weeks, from an initial concept straight through to the final delivery phase.

At friendlyway, ideas for new products are first discussed by a team made up of one developer, a controller, a sales professional, and a marketing expert. If these discussions are successful, initial designs are made for the planned product and reviewed by possible target groups outside the company.

If the outcome of these preliminary tests is also positive, the rapid prototyping phase is launched. In an effort to refine the product design further, three-dimensional views of the product are developed using highly advanced CAD computer programs. Finally, test models are assembled from wood, Styrofoam, and cardboard. Then the friendlyway Executive Board uses the model and 3D views to decide whether to approve funds for investment in a prototype. Once the investment is approved, the friendlyway development team starts incorporating the production partner into the planning process for the new product.

Many competing systems are made of cheap sheet steel. Customers can expect rust to appear on such products after only a short time. By contrast, the friendlyway classic series has been made of high-quality, non-corrosive aluminum ever since it was first introduced. This is the same material from which helicopter rotor blades are made. These are the hidden advantages friendlyway customers receive when they purchase a friendlyway system.

In China, it is an ancient tradition for great masters to copy the works of other artists. Chinese artists actually spend most of their lives trying to copy other masters as closely as possible. Not until the end of a successful artistic career do these artists add their own personal touch and become masters themselves. Being copied by other artists is a true affirmation of an artist's life's work. The Chinese view this as an expression of praise for the original.

While visiting a potential Chinese partner facility in Guangzhou province, friendlyway noticed that the company had already tried to copy friendlyway systems in China. During a meeting, the Chinese actually complained that the friendlyway products were manufactured with such extremely high quality. They had realized they needed a special tool just to produce the elegant friendlyway aluminum side sections. The tool would have required so much time and effort to develop that it was simply too costly for them in the end.

friendlyway is especially proud of its research cooperation with the University of the German Armed Forces (Bundeswehr), a project sponsored by the Bavarian government. The collaboration focuses on developing a completely new kind of outdoor display for extreme climate conditions. Because the project involves the development of fundamental technology, further details cannot be disclosed. In addition to providing special expertise in outdoor electronics applications, the Bundeswehr will also employ its spacious climate labs in the project. Any climate conditions occurring on the planet can be simulated in these special rooms.

Intangible benefits

friendlyway focuses on more than just the tangible value of its products. It also places great importance on intangible benefits. "We have noticed that customers normally want more than just components. Instead, they're usually looking for a solution to a concrete problem," says Alexander Plavinski, head of software development at friendlyway.

As a result, the company has invested heavily in the development of native standard software products in the past five years. "Our self-professed goal is to become the 'Apple of the kiosk and digital signage sector'," says Plavinski, a Belarus native. "This gives us the unique opportunity of optimizing hardware and software so they run in perfect harmony with each other. It'll be hard for competitors to do the same," says Plavinski with pleasure.

friendlyway also works with solution partners both at home and abroad to offer a wide range of special solutions for the friendlyway secure browser 7 and the friendlyway composer 7 software. Thanks to these partner solutions, customers can find the perfect solution for all their applications, from door signage and retail sales assistance to banks and trade-shows. In this way, customers receive all their services from a single source. This resolves the issue of responsibility in rare situations where a product fails to function properly.

The Echo

The company's many innovations and product enhancements have received resounding media attention. Time Magazine praised the friendlyway doorman solution by noting that "it doesn't even want a tip." Netinvestor magazine celebrated the company as one of Germany's 25 most innovative businesses. The German publication Focus has already mentioned friendlyway products as highlights of the CeBIT trade-show on several occasions. Business magazine Impulse has praised friendlyway products as "the new gateway to customers." Germany's Süddeutsche Zeitung called friendlyway "a pioneer in the supermarket of the future," and described the company's positioning as "an idea that will earn millions...."

In only its second year of existence, friendlyway was voted Bavaria's number-one startup company by the McKinsey strategy consulting firm, the Stern newspaper, and the German savings banks. Over 1200 other companies took part in the competition.

The company's founders Klaus Trox and Andreas Stütz proudly received their award from German Chancellor Dr. Angela Merkel. In her speech, the Chancellor praised friendlyway by saying "Innovative companies like friendlyway are safeguarding jobs in Germany."



SIEMENS MEDICAL, Malvern, USA

„With the friendlyway kiosks systems we had the fantastic situation to offer our product information via an interactive and easy-to-use platform. Many thanks to friendlyway.“



friendlyway History

Over the past ten years, friendlyway has shaped the kiosk and digital signage market more than any competitor. With an extensive product and service range, friendlyway is one of the world's most prominent holders of patents and copyrights.

1998-2009

Ten years of innovative development at friendlyway have resulted in a number of outstanding products:

1998

- 4.7 cm ultra-slim flatscreen kiosk
- Voice-controlled customer service system

1999

- Patented dirt-free monitor housing
- Kiosk with visual gesture recognition
- Bandwidth-independent video conferencing

2000

- Virtual sales advice system
- Linux-based surf terminal
- Virtual online shop
- MP3 music download station
- EC bankcard online payment function
- Talking product display (point-of-sale)
- Electronic car rental station
- Video-on-demand kiosk
- Download post for mobile consumer devices
- Weatherproof outdoor terminal
- CD burning kiosk

2001

- Interactive customer television (point-of-sale)
- Interactive terminal for controlling large-format screens
- Info post for mobile consumer devices with Wireless LAN
- Customer survey terminal

2002

- Multimedia memorial plate
- Video greeting terminal
- Elegant flatscreen kiosk
- Digital Signage software for controlling adscreens
- Bluetooth kiosk
- Electronic bank advisor
- Automatic business card scanner kiosk

2003

- Visitor welcoming display (foyers)
- Digital offertory box
- Waiter kiosk
- Table kiosk
- Virtual porter

2004

- Compact digital sign (on-shelf advertising)
- Electronic doorplate
- Security software for Internet access points
- Television on kiosks and digital signs
- Glass terminal kiosk
- Wedding terminal
- City information terminal
- Electronic event display
- Internet telephony for phone boxes
- Luminescent advertising kiosk
- Media master for digital and analog media
- Full-body kiosk with 40-inch touchscreen
- Easy-access kiosk with electronic height control (barrier-free)
- DVD player with motion sensor control
- Video counter with live video feed to call centers

2005

- Kiosk with document reader
- Digital sign with UMTS updating
- 60-inch touchscreen kiosk

2006

- Mobile-mounted digital sign
- Real estate terminal
- High-glare outdoor terminal

2007

- Automated visitor management
- Personalized visitor welcoming display (foyers)
- Mobile info kiosk with mobile power supply

2008

- Multimedia conference table
- Virtual catwalk
- Eco-efficient kiosk
- Digital ink doorplate

2009

- Professional Line: robust powder-coated metal system (a-sign, empire, porter, welcome)
- composer 9 software

friendlyway references



friendlyway is one of the few companies which has developed their own solution and software capability for kiosk and self service systems. The friendlyway software package was developed within the last seven years into one of the most powerful POI and POS software systems.

Our products and services have been distributed worldwide since the 90's. In the last 10 years, we have installed more than 25,000 friendlyway systems and software packages.

friendlyway kiosk solutions are among the best-selling and most reliable products in Europe and North America. The list of our customers is extensive. You can find a selection of reference projects and solutions for a variety of different branches in our „friendlyway-Solution-City“: www.friendlyway.com.

According to a current customer inquiry among more than 200 friendlyway customers, 98% of all customers are satisfied, very satisfied or enthusiastic about the success of the deployment of friendlyway systems.

All technical information and delivery details are subject to change. Errors and omissions excepted. Images of devices may not be fully representative of actual colors as a result of printer limitations.



Americas
friendlyway USA
Seattle, WA 98110
USA
Tel: +1 415 640 2023
Fax: +1 206 238 9966
E-Mail: michael.mccloud@friendlyway.com
Internet: www.friendlyway.com

EMEA
friendlyway AG
Feringastr. 9
85774 Unterföhring, Germany
Tel: +49 (0) 89 95 97 91 340
Fax: +49 (0) 89 95 97 91 40
E-Mail: info@friendlyway.com
Internet: www.friendlyway.com